

Residential Smart PV Solution (SmartAssistant Networking and SmartGuard Networking)

User Manual

Issue 09
Date 2025-12-30



Copyright © Huawei Digital Power Technologies Co., Ltd. 2026. All rights reserved.

No part of this document may be reproduced or transmitted in any form or by any means without prior written consent of Huawei Digital Power Technologies Co., Ltd.

Trademarks and Permissions



HUAWEI and other Huawei trademarks are the property of Huawei Technologies Co., Ltd.

All other trademarks and trade names mentioned in this document are the property of their respective holders.

Notice

The purchased products, services and features are stipulated by the contract made between Huawei Digital Power Technologies Co., Ltd. and the customer. All or part of the products, services and features described in this document may not be within the purchase scope or the usage scope. Unless otherwise specified in the contract, all statements, information, and recommendations in this document are provided "AS IS" without warranties, guarantees or representations of any kind, either express or implied. The information in this document is subject to change without notice. Every effort has been made in the preparation of this document to ensure accuracy of the contents, but all statements, information, and recommendations in this document do not constitute a warranty of any kind, express or implied.

Huawei Digital Power Technologies Co., Ltd.

Address: Huawei Digital Power Antuoshan Headquarters
Futian, Shenzhen 518043
People's Republic of China

Website: <https://digitalpower.huawei.com>

More Information

Huawei Digital Power Information Experience Center

<https://info.support.huawei.com/Energy/info>



About This Document

Purpose

This document describes the Residential Smart PV Solution (SmartAssistant & SmartGuard) in terms of the networking, cable connections, and device commissioning. The safety precautions, product introduction, site selection requirements, and maintenance information of the devices involved in the solution are described in the user manuals of the corresponding devices.

Statement

In this document, LUNA only refers to a specific model of Huawei Smart String ESS.

In this document, MERC only refers to a specific model of Huawei Smart PV Optimizer.

In this document, SmartGuard only refers to a specific model of Huawei SmartGuard.

In this document, SCharge only refers to a specific model of Huawei charger.





Intended Audience

This document is intended for:

- Sales engineers
- System engineers
- Technical support engineers
- End users

Symbol Conventions

The symbols that may be found in this document are defined as follows.

Symbol	Description
 DANGER	Indicates a hazard with a high level of risk which, if not avoided, will result in death or serious injury.
 WARNING	Indicates a hazard with a medium level of risk which, if not avoided, could result in death or serious injury.
 CAUTION	Indicates a hazard with a low level of risk which, if not avoided, could result in minor or moderate injury.
 NOTICE	Indicates a potentially hazardous situation which, if not avoided, could result in equipment damage, data loss, performance deterioration, or unanticipated results. NOTICE is used to address practices not related to personal injury.
 NOTE	Supplements the important information in the main text. NOTE is used to address information not related to personal injury, equipment damage, or environment deterioration.

Change History

Changes between document issues are cumulative. The latest document issue contains all the changes made in earlier issues.

Issue 09 (2025-12-30)

- Updated [1 Solution Overview](#).
- Updated [2.5.5 Three-Phase Imbalance Control](#).
- Updated [4.1.1 On/Off-Grid PV+ESS Scenario](#).
- Updated [6.1 Networking Application](#).
- Updated [6.2 Electrical Connections](#).

Issue 08 (2025-10-28)

- Updated [6.1.2 SmartGuard Networking](#).
- Updated [6.2 Electrical Connections](#).

Issue 07 (2025-09-30)

- Changed "Energy Management Assistant" to "SmartAssistant" throughout the document.
- Updated [1 Solution Overview](#).
- Updated [2.5.1 Setting ESS Parameters](#).
- Updated [3.5.4 Generator Settings](#).
- Updated [4.5.4 Generator Settings](#).
- Added [6 Networking with Third-Party Inverters](#).

- Updated [7.4.1 By the Same Installer](#).

Issue 06 (2025-07-01)

- Updated [1 Solution Overview](#).
- Updated [2.5.3 Grid-tied Point Control](#).
- Updated [5 Smart Appliance Networking](#).

Issue 05 (2025-01-20)

- Updated [2.5.6 Third-Party Management System Settings \(Connecting to Two Management Systems\)](#).
- Updated [7.4 Scenario Reconstruction](#).
- Updated [7.4.1 By the Same Installer](#).

Issue 04 (2024-10-30)

- Updated Networking with Third-Party Inverters.
- Updated [2.5.3 Grid-tied Point Control](#).
- Updated [7.4 Scenario Reconstruction](#).

Issue 03 (2024-04-30)

Added [4 Three-Phase SmartGuard Networking](#).

Issue 02 (2024-01-30)

Updated [2.1.1 PV+ESS System](#).

Issue 01 (2023-09-08)

This issue is the first official release.

Contents

About This Document	ii
1 Solution Overview	1
2 SmartAssistant Networking	7
2.1 Networking Application.....	7
2.1.1 PV+ESS System.....	8
2.2 Electrical Connections.....	11
2.3 System Power-On.....	12
2.4 Deploying a New Plant.....	14
2.5 Parameter Settings.....	15
2.5.1 Setting ESS Parameters.....	15
2.5.2 Peak Shaving.....	19
2.5.3 Grid-tied Point Control.....	20
2.5.4 Physical Layout of Optimizers.....	26
2.5.5 Three-Phase Imbalance Control.....	27
2.5.6 Third-Party Management System Settings (Connecting to Two Management Systems).....	28
2.6 System Power-Off.....	33
3 Single-Phase SmartGuard Networking	34
3.1 Networking Application.....	34
3.1.1 PV+ESS System.....	36
3.2 Electrical Connections.....	37
3.3 Powering On the System.....	38
3.3.1 Powering On the SmartGuard.....	38
3.3.2 Powering On Loads.....	41
3.4 Deploying a New Plant.....	42
3.5 Parameter Settings.....	43
3.5.1 Whole-House Power Backup Settings (Seamless Switchover).....	43
3.5.2 Setting Off-Grid Mode for the Inverter.....	44
3.5.3 (Optional) Setting the External WLAN Antenna.....	46
3.5.4 Generator Settings.....	46
3.5.5 Other Parameter Settings.....	49
3.6 System Power-Off.....	49
4 Three-Phase SmartGuard Networking	51

4.1 Networking Application.....	51
4.1.1 On/Off-Grid PV+ESS Scenario.....	53
4.2 Electrical Connections.....	62
4.3 System Power-On.....	63
4.3.1 Method 1: Power-On in On-Grid Mode or by Starting the Generator.....	63
4.3.1.1 Powering On the SmartGuard.....	63
4.3.1.2 Powering On Loads.....	66
4.3.1.3 Turning Off the Bypass Switch.....	66
4.3.2 Method 2: Power-On in Off-Grid Mode.....	67
4.3.2.1 Powering On the SmartGuard.....	68
4.3.2.2 Powering On Loads.....	70
4.4 Deploying a New Plant.....	70
4.5 Parameter Settings.....	71
4.5.1 Whole-House Power Backup Settings (Seamless Switchover).....	71
4.5.2 Setting Off-Grid Mode for the Inverter.....	73
4.5.3 (Optional) Setting the External WLAN Antenna.....	74
4.5.4 Generator Settings.....	75
4.5.5 Other Parameter Settings.....	78
4.6 System Power-Off.....	78
5 Smart Appliance Networking.....	80
5.1 Networking Application.....	80
5.2 Electrical Connections.....	83
5.3 Parameter Settings.....	84
6 Networking with Third-Party Inverters.....	85
6.1 Networking Application.....	85
6.1.1 SmartAssistant Networking.....	86
6.1.2 SmartGuard Networking.....	90
6.2 Electrical Connections.....	93
6.3 Parameter Settings.....	97
7 Maintenance and Replacement.....	99
7.1 Routine Maintenance.....	99
7.2 Troubleshooting.....	100
7.3 Replacing a Charger.....	100
7.4 Scenario Reconstruction.....	101
7.4.1 By the Same Installer.....	101
7.4.2 By Different Installers.....	104
8 Contact Us.....	107
A Connecting to the Inverter on the App.....	108
B Connecting to the SmartAssistant on the App.....	111
C Connecting to a Charger on the App.....	114

D Upgrading the Inverter.....	117
E Upgrading the Charger.....	118
E.1 Upgrading the Charger Software Version.....	118
E.2 What Should I Do If the Update Package Obtained from an iPhone Cannot Be Selected on the Update Screen?.....	119

1 Solution Overview

The residential Smart PV solution integrates a PV system and energy storage system (ESS) to convert solar energy into green electricity to meet residential power consumption requirements. When the sunlight is sufficient in the daytime, the PV system generates electricity and supplies it to home appliances, and the surplus electricity is used to charge the ESS. When the sunlight is insufficient, the ESS discharges to loads. In this scenario, green power generation and efficient power consumption are achieved through load scheduling and control.

Figure 1-1 Overview of the residential Smart PV solution

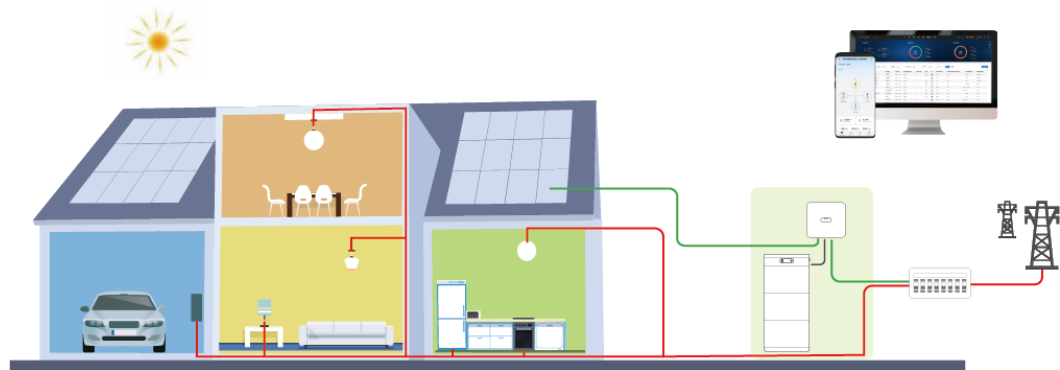

Solution Networking

The residential Smart PV solution involves two typical networking scenarios: SmartAssistant networking and SmartGuard networking.

- In the SmartAssistant networking scenario, home energy can be scheduled and managed in a unified manner.
 - PV and ESS features and smart loads are supported. In addition to unified scheduling and management of home energy, the SmartAssistant can connect to smart appliances such as heat pumps, heating rods, and smart circuit breakers as well as Huawei and third-party chargers. Users can set the reservation time to charge vehicles and heat water in advance at the specified time. In addition, users can set the priority to use PV power for devices as required to make the best use of PV power.
- In the SmartGuard networking scenario, the SmartGuard integrates the SmartAssistant and supports the on/off-grid switching in addition to functions

of home energy management and access to smart appliances. When the grid fails, the inverter switches to the off-grid state and supplies power to appliances connected to the backup power ports.

Table 1-1 List of networking features

Feature	SmartAssistant	Connect All Loads to the SmartGuard	Connect Some of Loads to the SmartGuard
PV+ESS self-consumption	√	√	√
Response time controlled at the grid connection point	2s	2s	2s
SmartAssistant	√	√	√
Heat pump and smart switch	√	√	√
Max. number of chargers	2	2	2
Power meter	Not required	Not required	Required ^[1]

 **NOTE**

Note [1]: The three-phase SmartGuard supports a maximum load current of 63 A. If the load current exceeds 63 A, only some of loads can be connected to it. In addition, a power meter needs to be connected between the three-phase SmartGuard and the main circuit breaker.

- If the power demand of loads exceeds the rated current of the main circuit breaker, the system will turn off the power supply to loads in the ascending order of power demand priority.

Products in the Solution

Table 1-2 Product list

Product	Model	Description
Inverter	Single-phase: SUN2000-(2KTL-6KTL)-L1 SUN2000-(8K, 10K)-LC0 series SUN2000-(3K-6K)-LB0 series SUN5000-(3K, 6K)-LB0 series Three-phase: SUN2000-(5KTL-12KTL)-M1 SUN2000-10KTL-BEM1 SUN2000-(8KTL-20KTL)-M2 SUN2000-(12KTL-25KTL)-M5 series SUN2000-(12K-25K)-MB0 series SUN2000-(5K-12K)-MAP0 series SUN5000-(8K, 12K)-MAP0 series SUN5000-(17K, 25K)-MB0 series	The inverter converts the PV power generated by the PV system.
ESS	LUNA2000-(5-30)-S0 LUNA2000-S1	Energy storage system, used for electricity charge and discharge.
SmartAssistant	SA4H-A02	Supports PV+ESS features and smart appliances.
SmartGuard	SmartGuard-63A-S0 and SmartGuard-63A-AUS0 (single-phase) SmartGuard-63A-T0 and SmartGuard-63A-AUT0 (three-phase)	<ul style="list-style-type: none"> Used for on/off-grid switchover of backup power for the whole house.
AC charger	SCharger-7KS-S0 (single-phase) SCharger-22KT-S0 (three-phase)	Multiple charge modes are available.
Optimizer	SUN2000-450W-P2 SUN2000-600W-P MERC-600W-PA0 MERC-(1300W, 1100W)-P	<p>For details about the mapping between inverters and optimizers, see:</p> <ul style="list-style-type: none"> SUN2000 Smart PV Optimizer User Manual MERC-600W-PA0 Smart PV Optimizer User Manual MERC-(1300W, 1100W)-P Smart PV Optimizer User Manual
Smart switch and heat pump	View 5.1 Networking Application to obtain the list of appliances that can be connected.	

 **NOTE**

- SUN5000 inverters cannot be cascaded with SUN2000 inverters.
- Optimizers must be configured for all PV modules connected to the SUN5000 inverter. Otherwise, the inverter cannot be started.
- The LUNA2000-(5-30)-S0 and LUNA2000-S1 cannot connect to the same inverter in a parallel system.
- In the inverter cascading scenario, if the devices networked meet the version requirements described in [Table 1-3](#), the LUNA2000-(5-30)-S0 and LUNA2000-S1 can connect to different inverters in the same plant.

Table 1-3 Device version requirements

Device	Version
SUN2000-(2KTL-6KTL)-L1	SUN2000L V200R001C00SPC153 or later
SUN2000-(3K-6K)-LB0	SUN2000LB V300R024C00SPC108 or later
SUN2000-(8K, 10K)-LC0	SUN2000LC V100R023C10SPC113 or later
SUN2000-(5KTL-12KTL)-M1	SUN2000MA V100R001C00SPC174 or later
SUN2000-10KTL-BEM1	SUN2000MA V100R001C00SPC174 or later
SUN2000-(12K-25K)-MB0	SUN2000MB V200R023C10SPC213 or later
SUN2000-(5K-12K)-MAP0	SUN2000MA V200R024C00SPC108 or later
SmartAssistant	SmartHEMS V100R025C00SPC120 or later
Single-phase SmartGuard	BackupBoxA V100R023C10SPC107
Three-phase SmartGuard	BackupBoxA V100R024C00SPC103
FusionSolar app	25.4.100 or later
FusionSolar Smart PV Management System (SmartPVMS)	SmartPVMS 25.3.0.5 or later

References

For details about the installation, cable connection, and configuration of the products in the network, see the following documents.

Table 1-4 Quick guides for the solution

Networking Scenario	Link
SmartAssistant networking	Residential Smart PV Solution Quick Guide (Single-Phase PV+ESS Scenario + SmartAssistant Networking)
	Residential Smart PV Solution Quick Guide (Three-Phase PV+ESS Scenario + SmartAssistant Networking)
SmartGuard networking	Residential Smart PV Solution Quick Guide (Single-Phase PV+ESS Scenario + SmartGuard Networking)
	Residential Smart PV Solution Quick Guide (Three-Phase PV+ESS Scenario + SmartGuard Networking)

Table 1-5 Product documents

Item	Link
Single-phase inverter	SUN2000-(2KTL-6KTL)-L1 Quick Guide
	SUN2000-(8K, 10K)-LC0 Series Quick Guide
	SUN2000-(3K-6K)-LB0 Series Quick Guide
	SUN5000-(3K, 6K)-LB0 Series Quick Guide
Three-phase inverter	SUN2000-(3KTL-10KTL)-M1 Quick Guide
	SUN2000-10KTL-BEM1 Quick Guide
	SUN2000-(8KTL-20KTL)-M2 Quick Guide
	SUN2000-(12KTL-25KTL)-M5 Series Quick Guide
	SUN2000-(12K-25K)-MB0 Series Quick Guide
	SUN2000-(5K-12K)-MAP0 Series Quick Guide
	SUN5000-(8K, 12K)-MAP0 Quick Guide
	SUN5000-(17K, 25K)-MB0 Series Quick Guide
ESS	LUNA2000-(5-30)-S0 Quick Guide
	LUNA2000-S1 Quick Guide
Charger	Smart Charger User Manual (SCharger-7KS-S0, SCharger-22KT-S0)
SmartAssistant	SA4H-A02 Quick Guide
SmartGuard	SmartGuard-63A-(S0, AUS0) Quick Guide
	SmartGuard-63A-(T0, AUT0) Quick Guide
Optimizer	SUN2000-(600W-P, 450W-P2) Smart PV Optimizer Quick Guide

Item	Link
	MERC-(1300W, 1100W)-P Smart PV Optimizer Quick Guide
	MERC-600W-PA0 Smart PV Optimizer Quick Guide
FusionSolar app	FusionSolar App Quick Guide (SmartAssistant)
Third-party charger, heat pump, heating rod, and smart switch	For details, see the quick guides delivered with the product.

2 SmartAssistant Networking

2.1 Networking Application

 NOTE

- Only one SmartAssistant can be connected to a router.
- It is recommended that the charger and SmartAssistant be connected to the router in wired network (FE) mode. If the charger and SmartAssistant are connected to the router in WLAN mode, the charging power may decrease due to unstable signals.
- Both the SmartAssistant and Smart Dongle provide communication capabilities. Only either of them can be installed in a power plant for networking. Otherwise, communication between devices will be abnormal.

2.1.1 PV+ESS System

Single Inverter

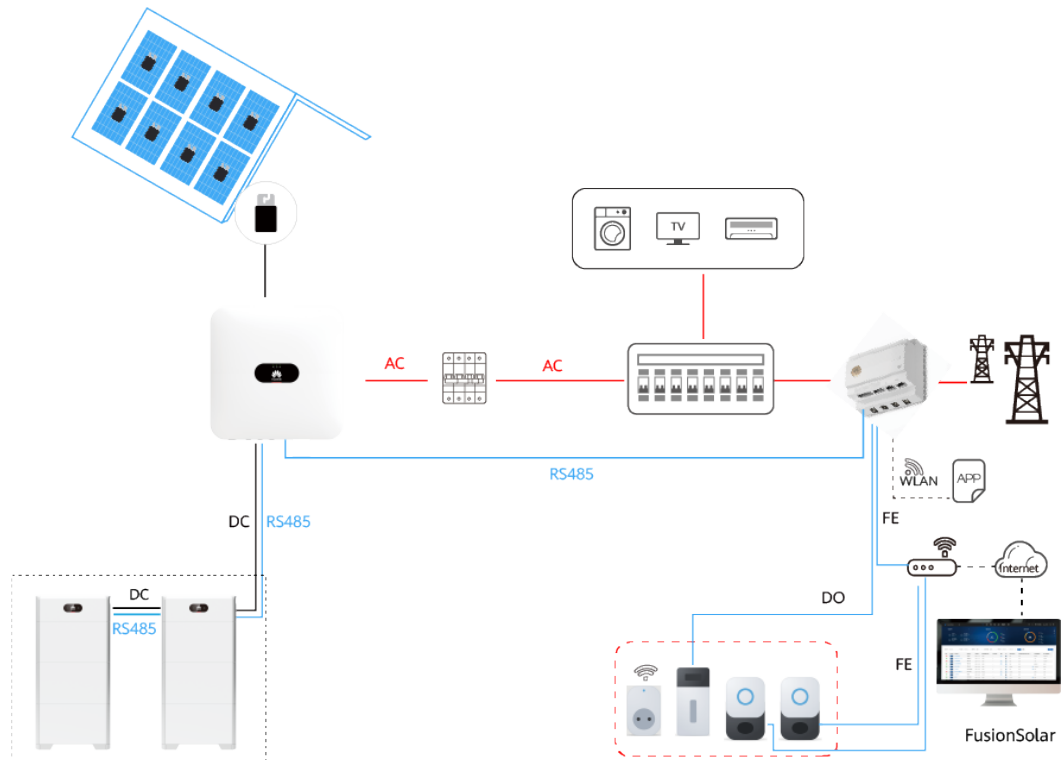

Note: The figure uses the LUNA2000-(5-30)-S0 as an example.

Table 2-1 Single-phase system configuration with the LUNA2000-(5-30)-S0

Inverter	LUNA2000-(5-30)-S0	Max. Number of Connected ESSs
SUN2000-(2KTL-6KTL)-L1	√	2
SUN2000-(8K, 10K)-LC0 Series	√	2
SUN2000-(3K-6K)-LB0 Series	√	2
SUN5000-(3K, 6K)-LB0 Series	√	2

Table 2-2 Single-phase system configuration with the LUNA2000-S1

Inverter	LUNA2000-S1	Max. Number of Connected ESSs
SUN2000-(2KTL-6KTL)-L1	√	2*
SUN2000-(8K, 10K)-LC0 Series	√	2
SUN2000-(3K-6K)-LB0 Series	√	2
SUN5000-(3K, 6K)-LB0 Series	√	2

 **NOTE**

If the SUN2000-(2KTL-6KTL)-L1 is connected to two ESSs (S1), the ESSs need to be connected to the SmartAssistant directly using an FE network cable or through a router.

Table 2-3 Three-phase system configuration with the LUNA2000-(5-30)-S0

Inverter	LUNA2000-(5-30)-S0	Max. Number of Connected ESSs
SUN2000-(3KTL-10KTL)-M1	√	2
SUN2000-10KTL-BEM1	√	2
SUN2000-(12K-25K)-MB0	√	4
SUN2000-(5K-12K)-MAP0 Series	√	2
SUN5000-(8K, 12K)-MAP0 Series	√	2
SUN5000-(17K, 25K)-MB0 Series	√	4

Table 2-4 Three-phase system configuration with the LUNA2000-S1

Inverter	LUNA2000-S1	Max. Number of Connected ESSs
SUN2000-(3KTL-10KTL)-M1	√	2
SUN2000-10KTL-BEM1	√	2

Inverter	LUNA2000-S1	Max. Number of Connected ESSs
SUN2000-(12K-25K)-MBO	√	4
SUN2000-(5K-12K)-MAP0 Series	√	2
SUN5000-(8K, 12K)-MAP0 Series	√	2
SUN5000-(17K, 25K)-MBO Series	√	4

Multiple Inverters Cascaded

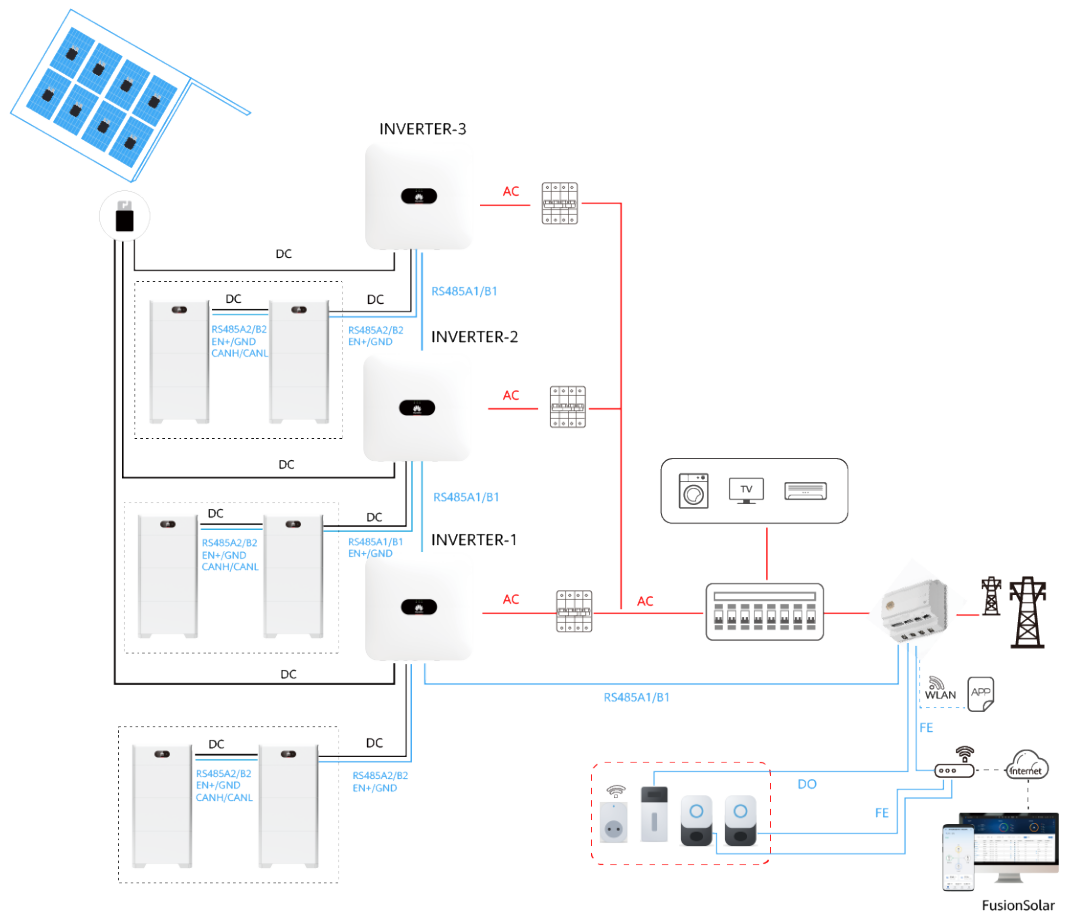

Table 2-5 Configuration description (single-phase system)

Inverter 1/2/3	Max. Number of Parallel Inverters
SUN2000-(2KTL-6KTL)-L1 SUN2000-(8K, 10K)-LC0 SUN2000-(3K-6K)-LB0 Series	3
SUN5000-(3K, 6K)-LB0 Series	3

Table 2-6 Configuration description (three-phase system)

Inverter 1/2/3	Max. Number of Parallel Inverters
SUN2000-(3KTL-10KTL)-M1 SUN2000-10KTL-BEM1 SUN2000-(8KTL-20KTL)-M2 SUN2000-(12KTL-25KTL)-M5 SUN2000-(12K-25K)-MB0	3
SUN2000-10KTL-BEM1	3
SUN2000-(5K-12K)-MAP0 Series	3
SUN5000-(8K, 12K)-MAP0 Series	3
SUN5000-(17K, 25K)-MB0 Series	3

 **NOTE**

A maximum of **three** inverters and **12** ESSs can be connected under SmartAssistant networking.

 **NOTE**

If an inverter is added in a parallel system, perform the manual baud rate negotiation by referring to the section "Baud Rate Negotiation" in the [SUN2000-\(12K-25K\)-MB0 Series User Manual](#).

2.2 Electrical Connections

For details about cable connections in typical scenarios, see the following table.

Table 2-7 Typical scenarios

Cable Connection Scenario	Documentation
Single-phase inverter + LUNA2000-(5-30)-S0 + SmartAssistant	Residential Smart PV Solution Quick Guide (Single-Phase PV+ESS Scenario + SmartAssistant Networking)

Cable Connection Scenario	Documentation
Single-phase inverter + LUNA2000-S1 + SmartAssistant	Residential Smart PV Solution Quick Guide (Three-Phase PV+ESS Scenario + SmartAssistant Networking)
Single-phase inverter + Third-party inverter + LUNA2000-(5-30)-S0 + SmartAssistant	
Single-phase inverter + Third-party inverter + LUNA2000-S1 + SmartAssistant	
Three-phase inverter + LUNA2000-(5-30)-S0 + SmartAssistant	
Three-phase inverter + LUNA2000-S1 + SmartAssistant	
Three-phase inverter + Third-party inverter + LUNA2000-(5-30)-S0 + SmartAssistant	
Three-phase inverter + Third-party inverter + LUNA2000-S1 + SmartAssistant	

2.3 System Power-On

DANGER

- Wear personal protective equipment and use dedicated insulated tools to avoid electric shocks or short circuits.
-

NOTICE

Before the equipment is put into operation for the first time, ensure that the parameters are set correctly by professional personnel. Incorrect parameter settings may result in noncompliance with local grid connection requirements and affect the normal operations of the equipment.

NOTICE

Before turning on the AC switch between the inverter and the grid, check that the AC voltage is within the specified range using a multimeter.

Check Before Power-On

Table 2-8 Checklist

No.	Check Item	Expected Result
1	Device installation	The device is installed correctly and securely.
2	Cable routing	Cables are routed properly as required by the customer.
3	Cable binding	Cable ties are evenly distributed and no sharp edge exists.
4	Grounding	The PE cable is connected correctly, securely, and reliably.
5	Switch	All switches are in the OFF state.
6	Cable connection	All cables are correctly and securely connected.
7	Unused terminal and port	Unused terminals and ports are locked by waterproof glands.
8	Installation environment	The installation space is proper, and the installation environment is clean and tidy.

Power-on Procedure

Step 1 Turn on the ESS switch.

Step 2 Turn on the main circuit breaker between the SmartAssistant and the grid.

Step 3 At the AC switch between the inverter and the SmartAssistant, use a multimeter to measure the grid voltage and ensure that the voltage is within the allowed operating voltage range of the inverter. If the voltage is not in the allowed range, check the circuits.

Step 4 Turn on the AC switch between the inverter and the SmartAssistant.

Step 5 Turn on the DC switch (if any) between the PV strings and the inverter.

Step 6 (Optional) Remove the knob locking screw next to the DC switch on the inverter.

Step 7 Turn on the DC switch on the inverter.

Step 8 Observe the LED indicators on the device to check the running status.

----End

2.4 Deploying a New Plant

Prerequisites

The charger must be upgraded to the FusionCharge V100R023C10 to match the SmartAssistant networking. Otherwise, the SmartAssistant cannot find the charger. [C Connecting to a Charger on the App](#) as an installer. For details about the upgrade operations, see [E Upgrading the Charger](#).

Setup Wizard

Figure 2-1 Deploying a new plant

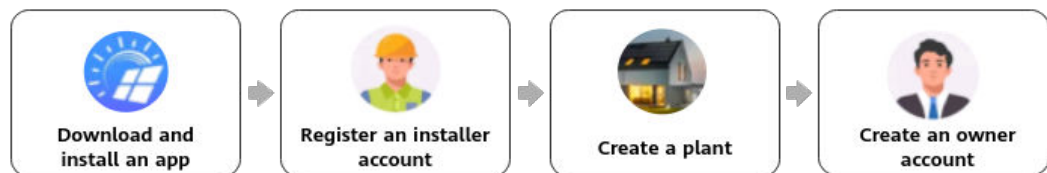

Table 2-9 Plant deployment description

No.	Task	Description
1	Downloading and installing an app	Download and install the FusionSolar app.
2	Registering an installer account	Register an installer account required for deployment and commissioning.
3	Creating a plant	Access the Setup wizard screen, scan the QR code to create a plant, commission devices according to the quick setting process, and connect devices to the plant.
4	Creating an owner account	Create an owner account that can be used to remotely monitor and manage devices.

- SmartAssistant networking: For details, see [FusionSolar App Quick Guide \(SmartAssistant\)](#). Scan the QR code of the SmartAssistant to create a plant.
- SmartGuard networking: For details, see [FusionSolar App Quick Guide \(SmartAssistant\)](#). Scan the QR code of the SmartGuard or SmartAssistant to create a plant.

NOTE

If the charger connects to the router over WLAN, you need to log in to the charger to set the WLAN information before deploying the SmartAssistant.

[Connect to the charger](#) as an installer, choose **O&M > Route Management**, select **WLAN** in **Connection Mode**, and enter the WLAN information.

Connection Test

Connection Test is supported in quick settings. You can perform this step to check whether the cable connections are correct, avoiding site visits for rectification.

Tap **Connection Test** and wait until the test is complete. If the test fails, rectify the fault in a timely manner.

2.5 Parameter Settings

NOTE

The app is being updated. The actual UI may vary.

Table 2-10 Setting process

Procedure	Step	
1. Deploying a new plant	(1) Download and install the FusionSolar app.	
	(2) Register an installer account. (Optional, required during initial registration)	
	(3) Follow the setup wizard.	a. Scan the QR code.
		b. Perform quick settings.
		c. Connect to the plant.
		d. Create an owner account.
e. View the plant status.		
(4) View the device status.		
2. Grid-tied point control (to be configured if limited feed-in is required; SmartAssistant required)		
3. Physical layout of optimizers (to be configured if optimizers are used)		
4. ESS end-of-discharge SOC		

2.5.1 Setting ESS Parameters

Connect the SmartAssistant on the app. Choose **Power adjustment > Battery control** on the home screen to set related parameters.

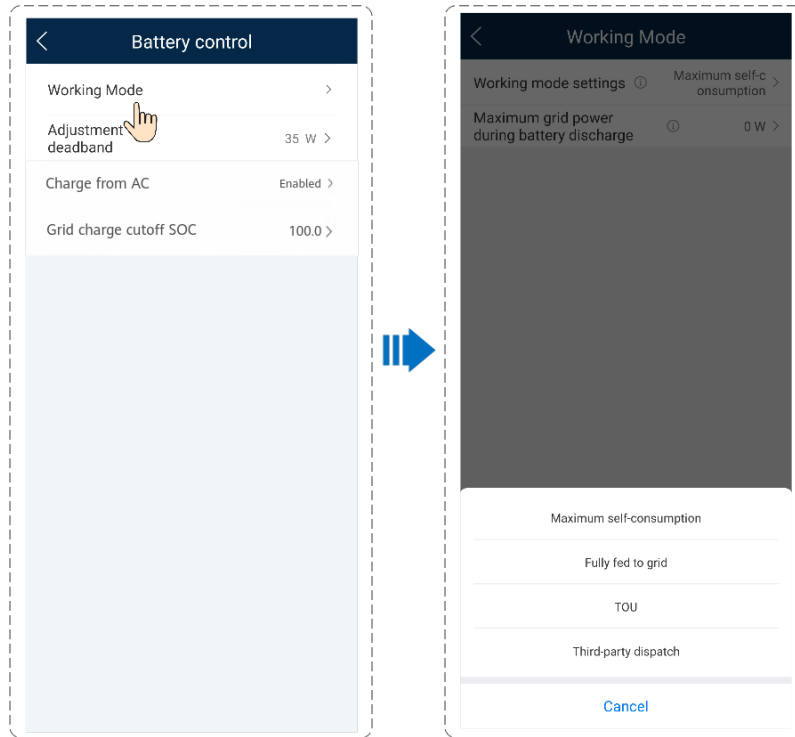

Connect the SmartAssistant on the app. Tap **Monitor** on the home screen, tap the corresponding inverter, tap **Set**, and set related parameters.

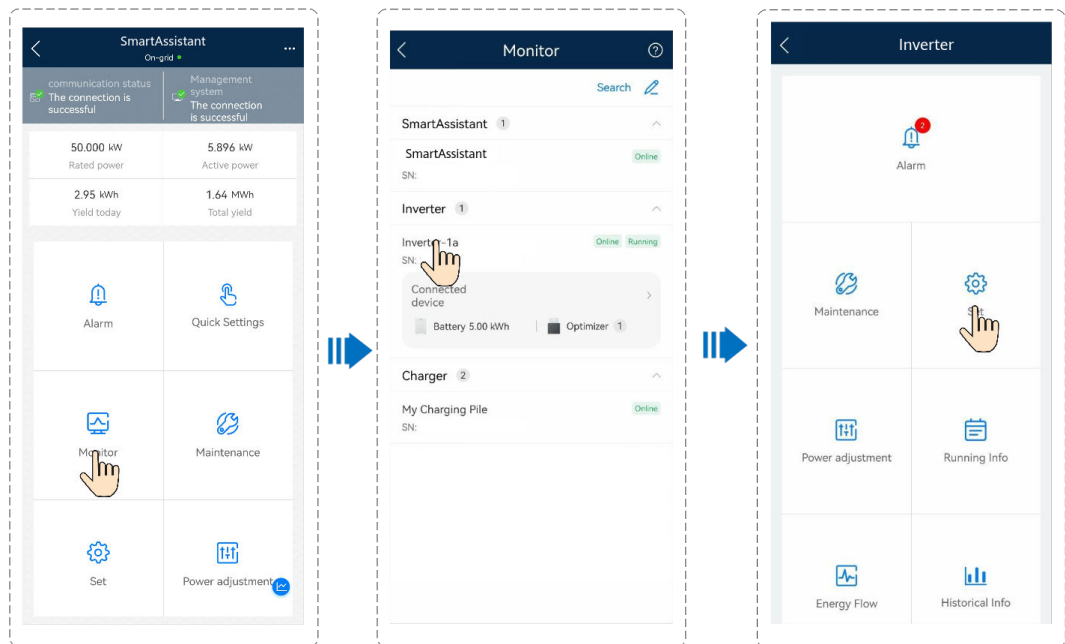

Battery Control

Table 2-11 Battery control parameters

Parameter	Description	Value Range
Working Mode	Set the working mode of the ESS.	<ul style="list-style-type: none"> • Maximum self-consumption • TOU • Fully fed to grid • Third-party dispatch: Only a third-party platform controls battery charge and discharge. <p>NOTE Before enabling Third-party dispatch, ensure that the system has been connected to the third-party management system.</p>
Adjustment deadband (W)	The SmartAssistant does not adjust the ESS power within the adjustment deadband range.	[0, 35]
Maximum charge power (kW)	Set the maximum charge power of the ESS.	Charge: [0.2, Maximum charge power]
Maximum discharge power (kW)	Set the maximum discharge power of the ESS.	Discharge: [0.2, Maximum discharge power]
End-of-charge SOC (%)	Set the end-of-charge SOC.	[90%, 100%]
End-of-discharge SOC (%)	Set the end-of-discharge SOC. If the battery SOC decreases to 0%, charge the battery in time. Otherwise, the battery capacity will fade irreversibly, and the resulting battery fault is not covered by the warranty. You are advised not to set the battery End-of-discharge SOC to 0.	[0, 20%]

Parameter	Description	Value Range
Charge from AC	Charge from AC is enabled by default. After this function is enabled, power can be purchased from the grid. Comply with the grid charge requirements stipulated in local laws and regulations when this function is enabled.	<ul style="list-style-type: none"> • Disabled • Enabled(default)
Maximum charge power of grid	Maximum charge power allowed by the grid. The value is determined by the local grid company. If there is no requirement, the value is the maximum charge power of the ESS by default.	[0, Maximum charge power of grid]
Grid charge cutoff SOC	Set the grid charge cutoff SOC.	[20%, 100%]
Maximum grid power during battery discharge	When the power purchased from the grid exceeds the preset threshold, the ESS starts discharging. The default value is 0. For example, if this parameter is set to 50 W and the load power is 40 W, 40 W power is purchased from the grid and the ESS does not discharge. If the load power is 100 W, 50 W power is purchased from the grid, and the ESS discharge power is 50 W.	[0, 1000]

 **NOTE**

If no PV modules are installed or the system has not detected sunlight for at least 24 hours, the minimum end-of-discharge SOC is 15%.

For the SUN2000-(3KTL-10KTL)-M1, SUN2000-(12K-25K)-MB0, and SUN5000-(17K, 25K)-MB0: If no PV modules are installed or the system has not detected sunlight for at least 24 hours, and the grid fails, the minimum end-of-discharge SOC is 15%.

Setting TOU Parameters

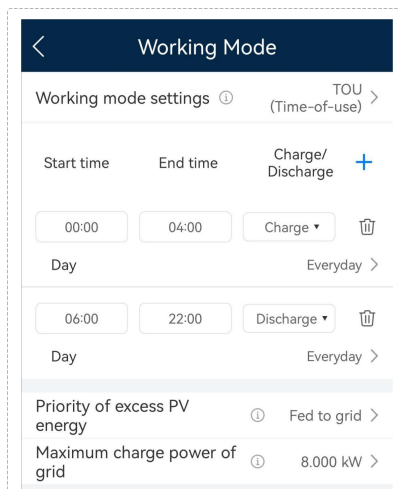

Parameter	Description	Value Range
Priority of excess PV energy	<ul style="list-style-type: none"> • Charge: When the PV power is greater than the load power, the surplus PV energy is used to charge the batteries. After the maximum charge power is reached or the batteries are fully charged, the surplus PV energy is fed to the grid. • Fed to grid: When the PV power is greater than the load power, the surplus PV energy is preferentially fed to the grid. When the maximum output power of the inverter is reached, the surplus energy is used to charge the batteries. This setting is applicable to the scenario where the feed-in tariff (FIT) is higher than the electricity price. The batteries are used only for backup power. 	<ul style="list-style-type: none"> • Charge • Fed to grid
Maximum charge power of grid	Maximum charge power allowed by the grid. The value is determined by the local grid company. If there is no requirement, the value is the maximum charge power of the ESS by default.	[0, Maximum charge power of grid]

2.5.2 Peak Shaving

Function

This function applies to areas that have peak demand charges. The peak shaving function allows you to lower the peak power drawn from grid in **Maximum self-consumption** or **TOU** mode during peak hours, reducing electricity fees.

NOTE

The peak shaving function cannot be used when the ESS working mode is set to **Fully fed to grid**.

Procedure

1. Log in to the local commissioning screen.
2. Choose **Power adjustment > Peak Shaving**, and set the working mode for peak shaving.

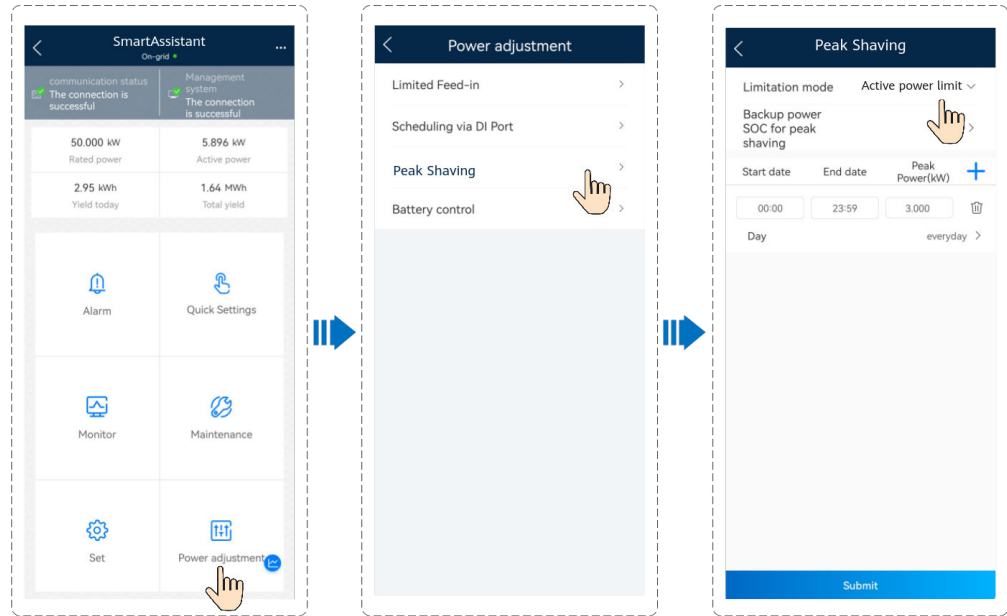

Parameter	Description	Value Range
Peak Shaving	To use Peak Shaving , you need to enable Charge from AC first.	<ul style="list-style-type: none"> No control Active power limit Apparent power limit
Backup power SOC for peak shaving (%)	The value of this parameter affects the peak shaving capability. A larger value indicates stronger peak shaving capability.	Backup power SOC for peak shaving > Backup power SOC (when Off-grid mode is enabled) > End-of-discharge SOC
Start date	<ul style="list-style-type: none"> Set the peak power range based on the start time and end time. The peak power is configured based on electricity prices in different time segments. You are advised to set the peak power to a low value when the electricity price is high. A maximum of 14 time segments can be set. 	-
End date		
Peak Power (kW)		[0.000, 1000.000]

NOTE

- For details about the peak shaving function, see the [Introduction to Peak Shaving](#).
- When chargers and smart loads work in a mode other than PV Power Preferred, the loads will not be reduced or turned off in response to peak shaving for demand limitation, ensuring normal use of loads.

2.5.3 Grid-tied Point Control

Many regions impose a limit on the feed-in power of a power generation system. Therefore, the power at the grid-tied point should be measured to control the

output of the inverter in real time, ensuring that the feed-in power meets the power requirement allowed by the grid.

Prerequisites

The SmartAssistant has been correctly installed at the grid-tied point. If an external CT is required, ensure that it is correctly installed.

Implementation

- **Control mode: Grid connected with zero power, Power-limited grid connected (%) or Limited feed-in (kW)**
- **Limitation mode: Single-phase power or Total power** (Select a mode based on the local grid requirements.)

Single-phase power: The power of each phase cannot exceed the preset limit. **Total power** (default): The total power of three phases cannot exceed the preset limit.

NOTE

In a three-phase system, if **Limitation mode** at the grid-tied point is set to **Total power**, a phase may have feed-in power. However, if **Control mode** is set to **Grid connected with zero power**, **Limitation mode** is set to **Single-phase power**, and only L1 has single-phase loads while the other two phases do not have loads, the loads on L1 can only be powered by the grid because the inverter sets the output of each phase to be 0.

Procedure

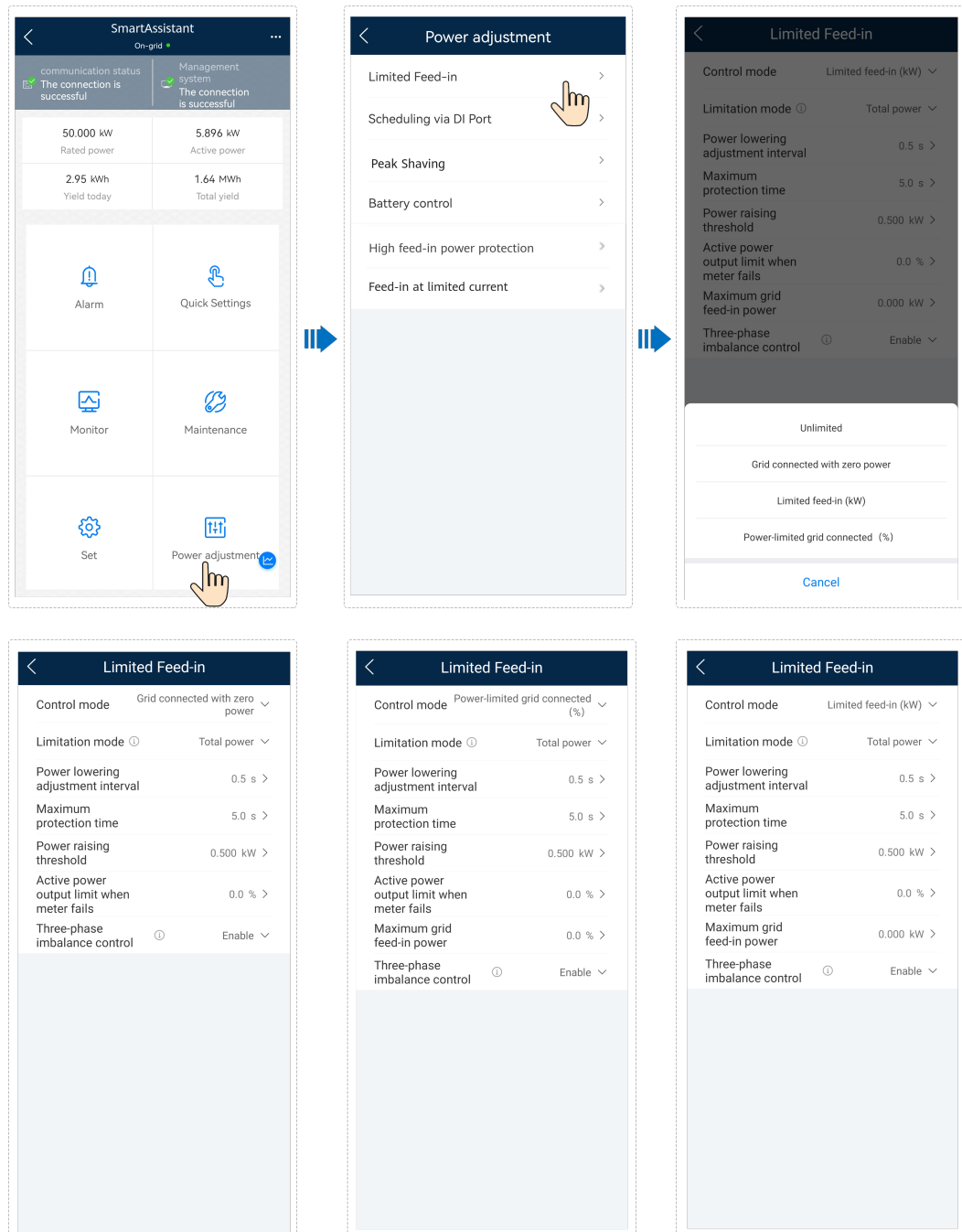

Parameter Description

NOTE

If you select limited feed-in, you need to set **Maximum grid feed-in power**.

Parameter		Description	
Control mode	Unlimited	-	If this parameter is set to Unlimited , the output power of the inverter is not limited and the inverter can connect to the grid at the rated power.
	Grid connected with zero power	Limitation mode	Total power indicates feed-in prevention of the total power at the grid-tied point. Single-phase power indicates feed-in prevention of the power in each phase at the grid-tied point.
		Power lowering adjustment interval	Interval for lowering the inverter output power.
		Maximum protection time	Maximum duration from the time when the SmartAssistant detects feed-in power to the time when the inverter output power is adjusted to 0.
		Power raising threshold	Inverter output power increase threshold. The recommended value is 1% to 2% Pn. Pn is the total rated power of the inverter.
		Active power output limit when meter fails	Derating value of the inverter active power in percentage when the SmartAssistant does not detect the meter data.
		Three-phase imbalance control	For details, see 2.5.5 Three-Phase Imbalance Control .
	Limited feed-in (kW)	Limitation mode	Total power indicates feed-in prevention of the total power at the grid-tied point. Single-phase power indicates feed-in prevention of the power in each phase at the grid-tied point.
		Power lowering adjustment interval	Interval for lowering the inverter output power.
		Maximum protection time	Maximum duration from the time when the SmartAssistant detects feed-in power to the time when the inverter output power is adjusted to 0.
		Power raising threshold	Inverter output power increase threshold. The recommended value is 1% to 2% Pn. Pn is the total rated power of the inverter.
		Active power output limit when meter fails	Derating value of the inverter active power in percentage when the SmartAssistant does not detect the meter data.
		Maximum grid feed-in power	Specifies the maximum active power transmitted from the grid-tied point to the power grid.

Parameter		Description
	Three-phase imbalance control	For details, see 2.5.5 Three-Phase Imbalance Control .
Power-limited grid connected (%)	Limitation mode	Total power indicates feed-in prevention of the total power at the grid-tied point. Single-phase power indicates feed-in prevention of the power in each phase at the grid-tied point.
	Power lowering adjustment interval	Interval for lowering the inverter output power.
	Maximum protection time	Maximum duration from the time when the SmartAssistant detects feed-in power to the time when the inverter output power is adjusted to 0.
	Power raising threshold	Inverter output power increase threshold. The recommended value is 1% to 2% P _n . P _n is the total rated power of the inverter.
	Active power output limit when meter fails	Derating value of the inverter active power in percentage when the SmartAssistant does not detect the meter data.
	Maximum grid feed-in power	Percentage of the maximum active power to the maximum active power at the grid-tied point.
	Three-phase imbalance control	For details, see 2.5.5 Three-Phase Imbalance Control .
	High feed-in power protection^a	Shutdown at high feed-in power
Upper feed-in power threshold for inverter shutdown		The default value is 0 . This parameter specifies the power threshold of the grid-tied point for triggering inverter shutdown.

Parameter		Description
	High feed-in power duration threshold for triggering inverter shutdown	<p>The default value is 20. This parameter specifies the duration threshold of high feed-in power for triggering inverter shutdown.</p> <ul style="list-style-type: none"> • When High feed-in power duration threshold for triggering inverter shutdown is set to 5, Shutdown at high feed-in power takes precedence. • When High feed-in power duration threshold for triggering inverter shutdown is set to 20, Limited Feed-in takes precedence (when Control mode is set to Limited Feed-in).
Feed-in at limited current^b	Max. feed-in current	<p>Value range: [0, 100 A]</p> <ul style="list-style-type: none"> • Due to external disturbances, the feed-in current may exceed the specified value by 2%. In this case, the inverter will adjust the current to a value within the range limit. • After the user changes the maximum feed-in current, the inverter will adjust the current to a value within the range limit. <p>If the maximum feed-in current is not adjusted to a value within the range limit within 15s, the inverter will shut down and report an alarm.</p>
	Max. grid supply current	<p>Value range: [0, 100 A]</p> <p>If the grid supply current exceeds the specified value by 2%, the inverter will adjust the current to a value within the range limit.</p>
	Restrict number of inverter startups	<ul style="list-style-type: none"> • If this parameter is set to Enable, the number of manual startups by choosing Enable after shutdown due to current adjustment failure cannot exceed three within 30 days. • If this parameter is set to Disable, the inverter does not limit the number of manual startups, which can then exceed three within 30 days.
	Array startup	All inverters in the array can be started manually.
<p>Note a: This parameter is supported only for the AS4777 or G99-TYPEA-LV grid code.</p> <p>Note b: This parameter is supported only for the G98 or G99-TYPEA-LV grid code.</p>		

 **NOTE**

To use the **Feed-in at limited current** function, the following version mapping requirements must be met.

Table 2-12 Version mapping

Device	Inverter Version	SmartAssistant Version	FusionSolar App Version
SUN2000-(2KTL-6 KTL)-L1	SUN2000L V200R001C00SPC 137 or later	SmartHEMS V100R023C10SPC 103 or later	24.6.0 or later
SUN2000-(12K-25 K)-MB0	SUN2000MB V200R023C10SPC 206 or later	SmartHEMS V100R024C00SPC 101 or later	24.6.100.007 or later
SUN5000-(17K, 25K)-MB0			
SUN2000-(5K-12K)-MAP0	SUN2000MA V200R024C00SPC 100 or later		
SUN5000-(8K, 12K)-MAP0			

2.5.4 Physical Layout of Optimizers

The Smart PV Optimizer is a DC-DC converter which implements maximum power point tracking (MPPT) of each PV module to improve the energy yield of the PV system. It also supports the module-level shutdown and monitoring functions.

If optimizers are configured for PV modules, you can view the physical location of each optimizer after creating a physical layout. If a PV module is faulty, you can quickly locate the faulty PV module from the physical layout to rectify the fault. If a PV module without an optimizer is faulty, you need to check the PV modules one by one to locate the faulty one, which is time-consuming and inefficient.

For details about the physical location layout of the optimizers, see [FusionSolar Physical Layout User Guide](#).

Figure 2-2 Viewing a physical layout on the FusionSolar app

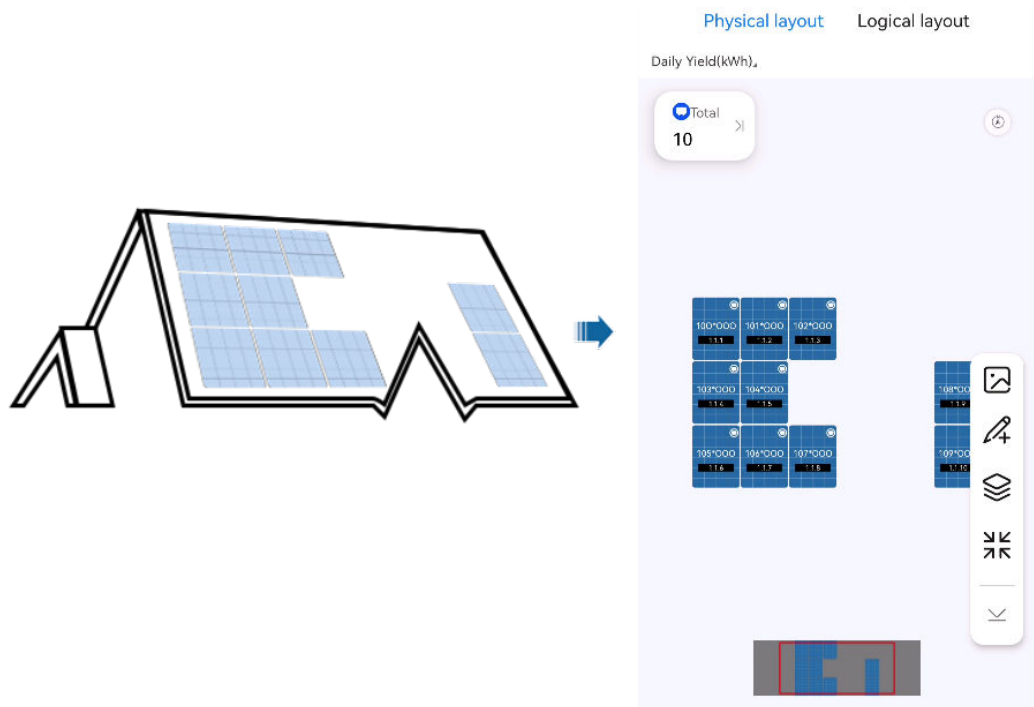
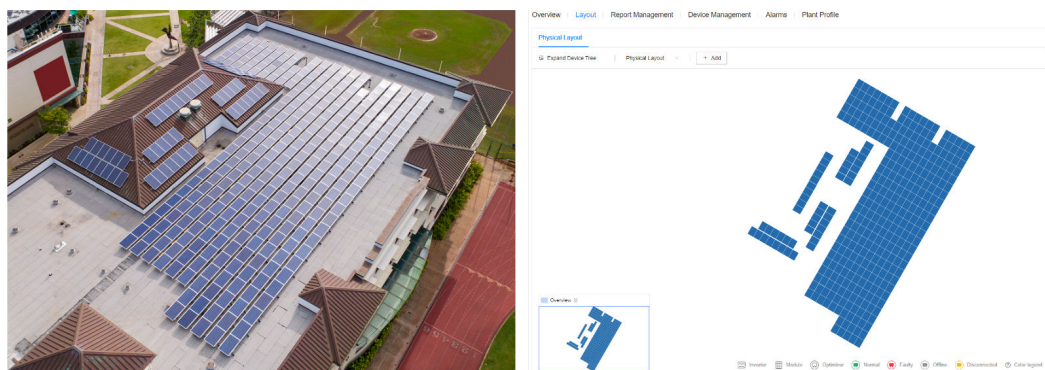

Figure 2-3 Viewing a physical layout on the SmartPVMS



2.5.5 Three-Phase Imbalance Control

NOTE

Only the SUN2000-(5K-12K)-MAP0 and SUN5000-(8K, 12K)-MAP0 inverters support three-phase imbalance control.

During feed-in at limited current or limited single-phase power, the MAP0 runs with three-phase imbalance control by default.

Function Description

Three-phase imbalance control applies to the following scenarios:

- Asymmetric phase feeding with feed-in limitation: The feed-in power of each phase in the three-phase power grid cannot exceed the preset threshold. The inverter outputs different power for each phase based on the loads of each

phase to ensure that the feed-in power of each phase does not exceed the preset threshold.

- PV+ESS asymmetric phase feeding for self-consumption: When the ESS discharges power to the loads, the inverter outputs phase-specific power based on the load of each phase and tracks the loads on each phase to ensure that no ESS discharge power is fed to the grid while the PV power can be fed to the grid.

The preceding two scenarios are supported concurrently.

 NOTE

Three-phase imbalance control is supported in the SmartAssistant networking scenario where only one inverter is applied or multiple inverters are connected in parallel.

Prerequisites

- Choose **Device monitoring > Inverter > Settings** and check that **Output mode** is set to **Three-phase, four-wire** and **Meter Connection Mode** in **Settings** is set to **Three-phase four-wire**.
- In the asymmetric phase feeding with feed-in limitation scenario, choose **Power adjustment > Limited Feed-in** and check that **Limitation mode** is set to **Single phase power**.
- In the PV+ESS asymmetric phase feeding for self-consumption scenario, choose **Power adjustment > Battery control** and check that **Working Mode** is set to **Maximum self-consumption** or **TOU**.

Procedure

1. Log in to the local commissioning screen.
2. Choose **Power adjustment > Split Phase Power Control** and set **Three-phase imbalance control** to **Enable**.

2.5.6 Third-Party Management System Settings (Connecting to Two Management Systems)

Prerequisites

If the SmartAssistant connects to a third-party management system, you also need to connect the SmartAssistant to Huawei management system to facilitate inverter O&M.

 NOTE

The FusionSolar app 24.6.0 or later can connect to a third-party management system.

Method 1: Connecting to the SmartAssistant and Setting Third-Party Management System Parameters

- Step 1** [Connect to the SmartAssistant](#), choose **Set > Communication settings > Third-Party Management System Configuration**, and set third-party management system parameters.

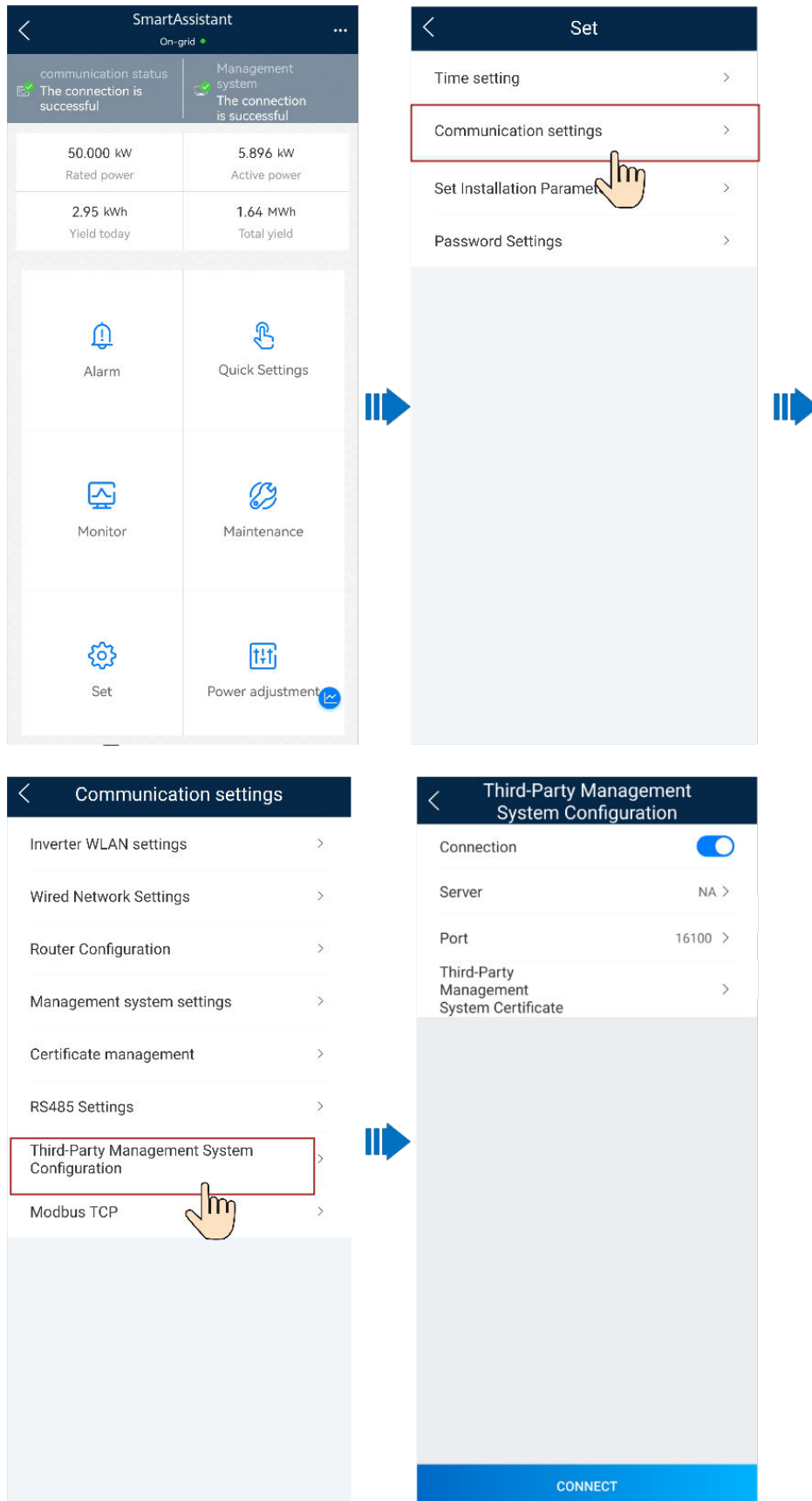

Table 2-13 Parameter settings

Parameter	Description	Value Range
Connection	<ul style="list-style-type: none">The default value is Disable, meaning that a third-party management system cannot be connectedWhen this parameter is set to Enable, a third-party management system can be connected.	<ul style="list-style-type: none">DisableEnable
Server	Domain name or IP address.	-
Port	Server port.	[1, 65535]
Third-Party Management System Certificate	-	[Root certificate, Customer certificate, Key file, Key password]

----End

Method 2: Logging In to the FusionSolar Smart PV Management System and Setting Third-Party Management System Parameters

- Log in to the FusionSolar app and tap the plant name on the **Home** screen to access the plant screen. Choose **Devices**, select the SmartAssistant to be set, tap **Parameter settings**, and set parameters as prompted.

Figure 2-4 Setting third-party management system parameters

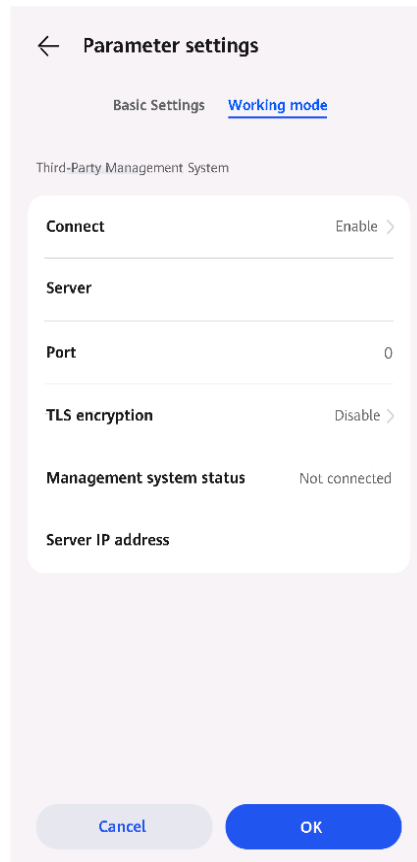

- Log in to <https://intl.fusionsolar.huawei.com> to access the WebUI of the FusionSolar SmartPVMS. On the **Home** page, click the plant name to go to the plant page. Select the SmartAssistant to be set, click **Configuration**, and set parameters as prompted.

Figure 2-5 Setting third-party management system parameters

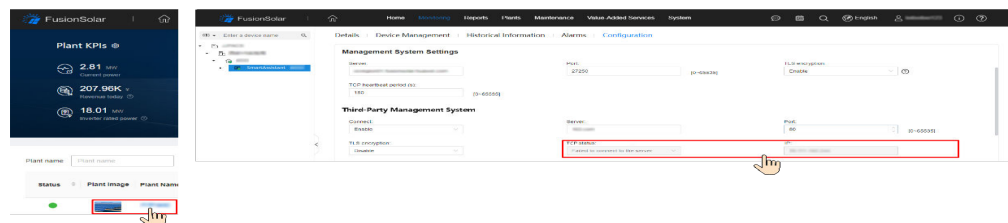

Table 2-14 Parameter settings

Parameter	Description	Value Range
Connect	<ul style="list-style-type: none"> • The default value is Disable, meaning that a third-party management system cannot be connected. • When this parameter is set to Enable, a third-party management system can be connected. 	<ul style="list-style-type: none"> • Disable • Enable
Server	Domain name.	-

Parameter	Description	Value Range
Port	Server port.	[0, 65535]
TLS encryption	<ul style="list-style-type: none"> If the third-party management system uses the TLS encryption protocol, set this parameter to Enable. If this parameter is set to Enable, select a version based on the TLS version of the third-party management system. If the third-party management system does not use the TLS encryption protocol, set this parameter to Disable. 	<ul style="list-style-type: none"> Disable Enable
TCP status	Connection status of the third-party management system.	<ul style="list-style-type: none"> Not connected Internal error. Resources are insufficient. Connection Successful Connection deadlock The peer end is disabled Connection abnormal Failed to connect to the port Failed to verify the peer certificate The local certificate is abnormal Domain name resolution failed Failed to connect to the server Connecting... Second challenge authentication failed
IP	Server IP address	-

The CA certificate of the third-party management system can be imported to Huawei's device to ensure encrypted connection. Before import, ensure that the third-party management system is successfully connected.

On the **Plants** page, choose **Device Certificate Management > Trust Certificates**, click **Import Locally**, and perform operations as prompted.

2.6 System Power-Off

Precautions

 **WARNING**

- After the system powers off, the remaining electricity and heat may still cause electric shocks and burns. Therefore, wait for 5 minutes after the system is powered off, wear protective gloves, and then perform operations on the ESS. You can maintain the ESS only when all indicators on the ESS are off.
 - When the ESS is running, if you only turn off the DC switch of the ESS, the system is not completely powered off. In this case, do not maintain the ESS.
-

Procedure

Step 1 Turn off the main switch between the SmartAssistant and the grid.

Step 2 Turn off the AC switch between the inverter and the SmartAssistant.

Step 3 Power off the inverter.

1. Send a shutdown command to the inverter on the app.
2. Set the **DC SWITCH** of the inverter to **OFF**.
3. (Optional) Install the locking screw for the **DC SWITCH**.
4. (Optional) Turn off the DC switch between the inverter and PV strings.

Step 4 Shut down the ESS.

1. Set the **DC SWITCH** of the ESS to **OFF**.
2. (Optional) Install the locking screw for the **DC SWITCH** of the ESS.

----End

3 Single-Phase SmartGuard Networking

3.1 Networking Application

 **CAUTION**

- If the main circuit breaker's rating is 63 A or less, you can connect all or some of the loads to the SmartGuard. However, if the rating is greater than 63 A, you can connect only some of the loads to the SmartGuard.
 - If the generator deployed in the power plant runs in off-grid mode and the load power exceeds the generator capacity, the generator may shut down due to overload. You are advised to shut down some loads.
 - If the power of backup loads exceeds the maximum off-grid power of the system, the inverter may be shut down due to overload. In this case, you need to shut down some loads. Alternatively, connect loads with lower priority to the non-backup load port.
-

NOTICE

- If a charger is configured, the charger must be installed on a non-backup power port.
-

Step 1 Residential load classification (dashed boxes indicate optional components)

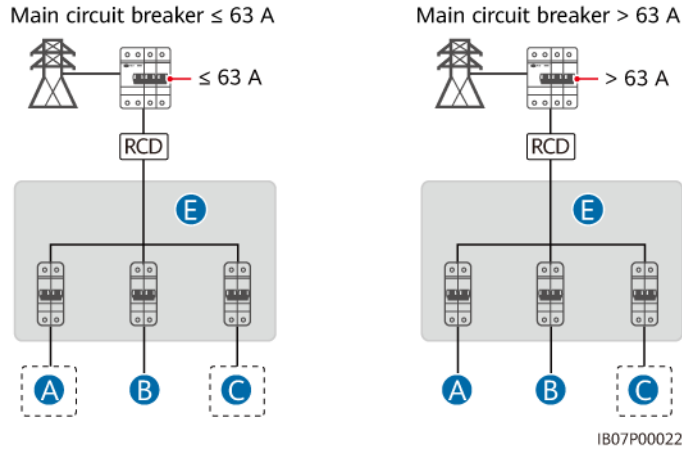

Main Circuit Breaker	Connect All Loads to the SmartGuard	Connect Some of Loads to the SmartGuard
≤ 63 A	Supported	Supported
> 63 A	Not supported	Supported

Step 2 Classification of loads connected to the SmartGuard (dashed boxes indicate optional components)

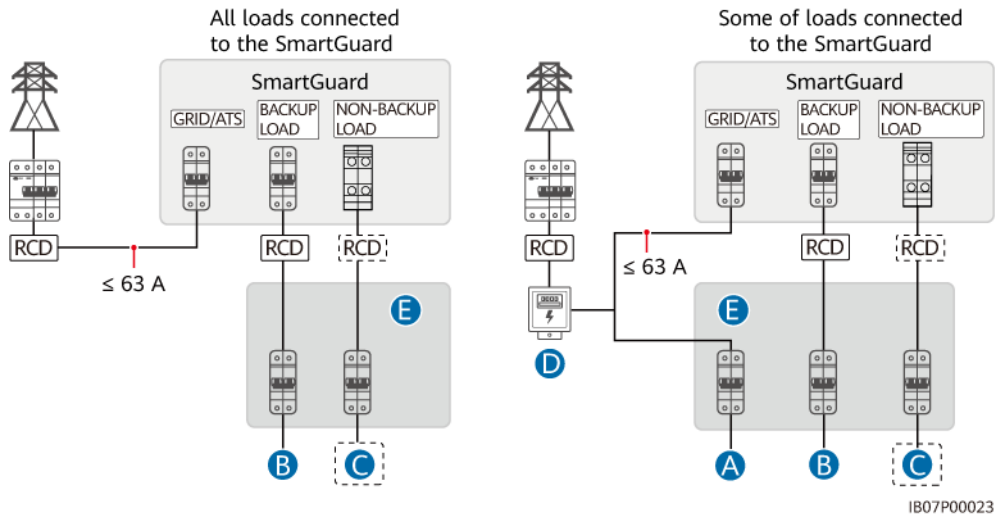

- (A) Load not connected to the SmartGuard
- (B) Backup load
- (C) Non-backup load
- (D) Power meter
- (E) AC power distribution box

----End

3.1.1 PV+ESS System

DANGER

- An RCD must be installed before the backup load. During off-grid operation, the main circuit breaker does not provide protection. Electric leakage on the loads may result in electric shocks. The rated leakage current must be greater than or equal to the number of inverters multiplied by 100 mA.
- The main circuit breaker with the leakage protection function must be installed. The rated leakage current must be greater than or equal to the number of inverters multiplied by 100 mA.

NOTE

- The SmartAssistant in the SmartGuard can be connected to the router over FE or WLAN. If WLAN is used, the SmartGuard must be installed close to the router.
- Both the SmartAssistant in the SmartGuard and the Smart Dongle provide communication capabilities. Only either of them can be installed in a power plant for networking. Otherwise, communication between devices will be abnormal.
- It is recommended that the charger and the SmartAssistant in the SmartGuard be connected to the router in wired network (FE) mode. If the charger is connected to the router in WLAN mode, the communication may be interrupted due to unstable signals.
- The SmartGuard-63A-(S0, AUS0) can be connected to only one inverter.
 - Connect the SUN2000-(8K, 10K)-LC0 or SUN2000-(8K, 10K)-LC0-ZH to the INV1 63A port of the SmartGuard.
 - Connect the SUN2000-(2KTL-6KTL)-L1, SUN2000-(3K-6K)-LB0, or SUN5000-(3K, 6K)-LB0 to the INV2 32A port of the SmartGuard.

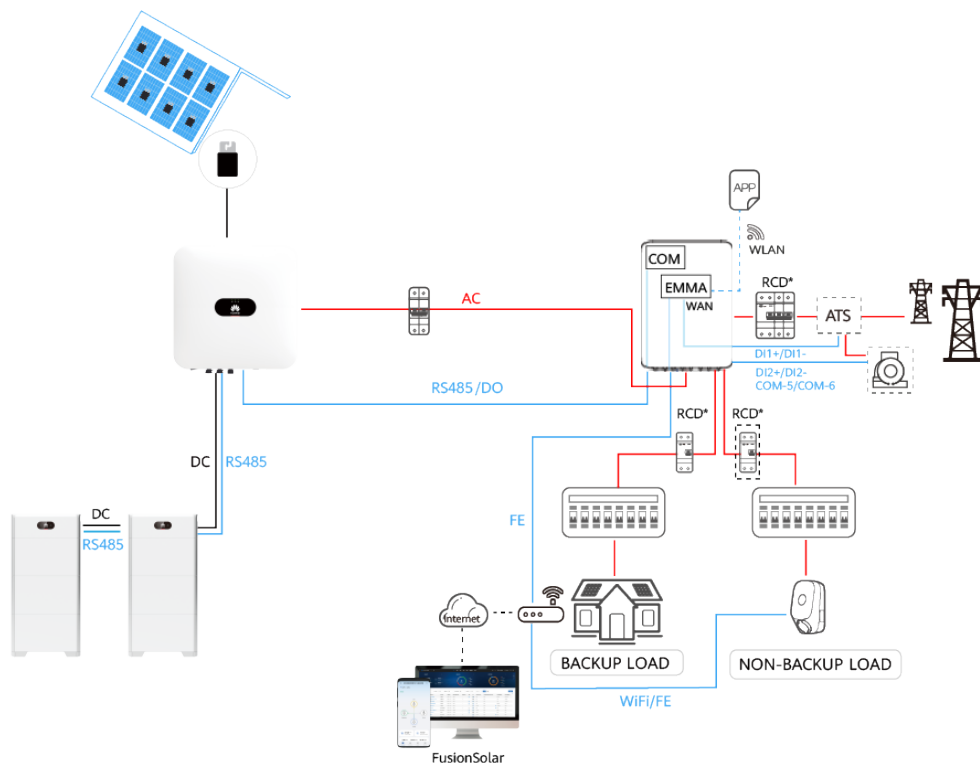

Note: The figure uses the LUNA2000-(5-30)-S0 as an example.

Table 3-1 SmartGuard networking with the LUNA2000-(5-30)-S0

Inverter	LUNA2000-(5-30)-S0	Max. Number of Connected ESSs
SUN2000-(2KTL-6KTL)-L1	√	2
SUN2000-(8K, 10K)-LC0/ SUN2000-(8K, 10K)-LC0-ZH	√	2
SUN2000-(3K-6K)-LB0	√	2
SUN5000-(3K, 6K)-LB0	√	2

Table 3-2 SmartGuard networking with the LUNA2000-S1

Inverter	LUNA2000-S1	Max. Number of Connected ESSs
SUN2000-(2KTL-6KTL)-L1	√	2*
SUN2000-(8K, 10K)-LC0/ SUN2000-(8K, 10K)-LC0-ZH	√	2
SUN2000-(3K-6K)-LB0	√	2
SUN5000-(3K, 6K)-LB0	√	2

 **NOTE**

If the SUN2000-(2KTL-6KTL)-L1 is connected to two ESSs (S1), the ESSs need to be connected to the SmartAssistant directly using an FE network cable or through a router.

3.2 Electrical Connections

For details about cable connections in typical scenarios, see the following table.

Table 3-3 Single-phase PV+ESS system + SmartGuard networking

Cable Connection Scenario	Documentation
Single-phase inverter + LUNA2000-(5-30)-S0 + SmartGuard-63A-S0/AUS0	Residential Smart PV Solution Quick Guide (Single-Phase PV+ESS Scenario + SmartGuard Networking)
Single-phase inverter + LUNA2000-(7, 14, 21)-S1 + SmartGuard-63A-S0/AUS0	

3.3 Powering On the System

3.3.1 Powering On the SmartGuard

NOTICE

- If the high-power load configured for the power plant is connected to the non-backup load port of the SmartGuard or is connected outside the SmartGuard, choose power-on in on-grid mode for device commissioning when the power plant is powered on for the first time. If you choose power-on in off-grid mode, the high-power load cannot be detected because it is not powered on during device commissioning.
 - If some of loads in the power plant are connected to the SmartGuard, choose power-on in on-grid mode or by starting the generator for device commissioning when the plant is powered on for the first time. If you choose power-on in off-grid mode, the external power meter cannot be detected during device commissioning because it is not powered on.
-

Method 1: Power-On in On-Grid Mode

Step 1 Use a multimeter to check whether the AC voltage in the power distribution box is within the allowed range and whether cables are correctly connected.

Step 2 Turn on the ESS switch.

1. (Optional) Remove the locking screw for the **DC SWITCH** of the ESS.
2. Set the **DC SWITCH** of the ESS to ON.
3. (Optional) Press and hold the black start button for 5s if the PV strings are equipped with optimizers or receive no solar irradiance.

Step 3 Power on the inverter.

1. (Optional) Turn on the DC switch (if any) between the PV strings and the inverter.
2. (Optional) Remove the locking screw for the **DC SWITCH** of the inverter.
3. Set the **DC SWITCH** of the inverter to ON.

Step 4 Turn on the main circuit breaker.

Step 5 Check that the SmartGuard is running in on-grid mode. Observe the LED indicators on the inverter, ESS, SmartAssistant, and SmartGuard to check the running status.

----End

Method 2: Power-On in Off-Grid Mode

NOTE

If the PV strings are equipped with optimizers, power-on in off-grid mode is not supported.

- Step 1** Keep the main circuit breaker off.
- Step 2** Turn on the ESS switch.
1. (Optional) Remove the locking screw for the **DC SWITCH** of the ESS.
 2. Set the **DC SWITCH** of the ESS to ON.
 3. Press and hold the black start button for 5s.
- Step 3** Power on the inverter.
1. (Optional) Turn on the DC switch (if any) between the PV strings and the inverter.
 2. (Optional) Remove the knob locking screw for the **DC SWITCH** of the inverter.
 3. Set the **DC SWITCH** of the inverter to ON.
- Step 4** [Connecting the Inverter on the App](#). Set the grid code of the inverter and then set off-grid mode of the inverter. For details, see method 2 in [3.5.2 Setting Off-Grid Mode for the Inverter](#).
- Step 5** (Optional) [Connecting the Inverter on the App](#). Upgrade the SUN2000-(2KTL-6KTL)-L1 inverter. Otherwise, the SmartGuard may fail to identify the inverter. For details, see [Upgrading the Inverter](#).
- Step 6** Check that the SmartGuard is running in off-grid mode. Observe the LED indicators on the inverter, ESS, SmartAssistant, and SmartGuard to check the running status.
- End

Method 3: Power-On by Starting the Generator

 **NOTE**

During system upgrade, manually start the generator on the generator control panel to prevent upgrade failures caused by generator shutdown.

- Step 1** On the control panel of the generator, manually start the generator. Use a multimeter to check that the AC voltage in the power distribution box is within the allowed range and that cables are correctly connected.
- Step 2** Turn on the main circuit breaker.
- Step 3** Turn on the ESS switch.
1. (Optional) Remove the locking screw for the **DC SWITCH** of the ESS.
 2. Set the **DC SWITCH** of the ESS to ON.
- Step 4** Power on the inverter.
1. (Optional) Turn on the DC switch (if any) between the PV strings and the inverter.
 2. (Optional) Remove the locking screw for the **DC SWITCH** of the inverter.
 3. Set the **DC SWITCH** of the inverter to ON.

Step 5 Check that the SmartGuard is running in on-grid mode. Observe the LED indicators on the inverter, ESS, SmartAssistant, and SmartGuard to check the running status.

----End

LED Indicators on the SmartAssistant and SmartGuard

Table 3-4 SmartAssistant indicator description





Indicator	Status	Description
Running status indicator 	Off	The system is not powered on.
	Steady green	The system is powered on and running.
Alarm indicator 	Off	No alarm is raised.
	Blinking red slowly (on for 1s and then off for 4s)	The system raises a warning alarm.
	Blinking red fast (on for 0.5s and then off for 0.5s)	The system raises a minor alarm.
	Steady red	The system raises an urgent/critical alarm.
Communication status indicator 	Off	The IP address of the management system server is not configured. (The indicator is off when the SmartAssistant is not connected to the FusionSolar SmartPVMS.)
	Blinking green slowly (on for 1s and then off for 1s)	The communication with the management system is normal.
	Blinking green fast (on for 0.125s and then off for 0.125s)	The communication with the management system is interrupted.

Table 3-5 Indicators on the SmartGuard

Indicator	Status	Description
	Steady green	The SmartGuard is in on-grid mode.
	Blinking green slowly	(Reserved) The SmartGuard is in generator off-grid mode.
	Steady orange	The SmartGuard is in inverter off-grid mode.
	Steady red	A hardware alarm is generated on the SmartGuard.
	Blinking red slowly	An environment alarm is generated on the SmartGuard.

3.3.2 Powering On Loads

Method 1: Power-On in On-Grid Mode and Power-On by Starting the Generator

- Step 1** Check that the inverter, ESS, SmartAssistant, and SmartGuard are working properly in on-grid mode.
- Step 2** (Optional) Turn off switches for high-power home appliances to avoid generator overload.
- Step 3** After checking that the residential load circuit is not short-circuited, turn on the backup load and non-backup load switches.
- Step 4** (Optional) Set Huawei charger route parameters.

----End

Method 2: Power-On in Off-Grid Mode (with PV Strings)

 **CAUTION**

- The power and current of backup loads cannot exceed the maximum off-grid power and current of the system. You are advised to shut down high-power loads and unnecessary loads connected to the backup load port.
 - If the battery SOC is less than **End-of-discharge SOC**, charge the ESS from the PV strings until the ESS is charged to **End-of-discharge SOC** plus 10% or higher.
-

- Step 1** Check that the inverter, ESS, SmartAssistant, and SmartGuard are working properly in off-grid mode.
- Step 2** Check that the residential backup load power does not exceed the off-grid operating power of the inverter.

Step 3 After checking that the residential load circuit is not short-circuited, turn on the backup load and non-backup load switches.

----End

3.4 Deploying a New Plant

Figure 3-1 Deploying a new plant

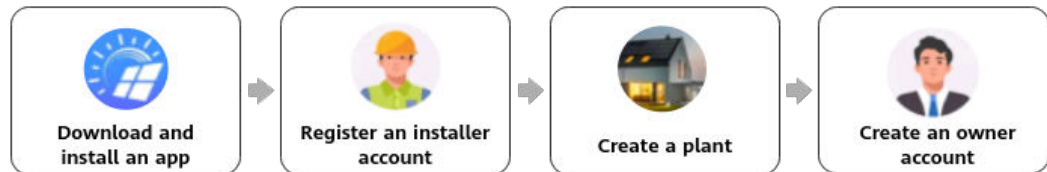

Table 3-6 Plant deployment description

No.	Task	Description
1	Downloading and installing an app	Download and install the FusionSolar app.
2	Registering an installer account	Register an installer account required for deployment and commissioning.
3	Creating a plant	Access the Setup wizard screen, scan the QR code to create a plant, commission devices according to the quick setting process, and connect devices to the plant.
4	Creating an owner account	Create an owner account that can be used to remotely monitor and manage devices.

NOTE

- For details about new plant deployment and existing plant revamping, see [FusionSolar App Quick Guide \(SmartAssistant\)](#) or scan the QR code.
- In the existing plant revamping scenario, the SmartGuard and Dongle cannot be used at the same time. You need to remove the Dongle from the inverter. The SmartGuard has a built-in power meter. If all loads are connected to the SmartGuard, the original power meter in the power plant needs to be directly removed. If some of loads are connected to the SmartGuard, a power meter of the recommended model must be used and its cables need to be reconnected. For details about the cable connections.
- For details about how to set ESS parameters, inverter parameters, and physical layout of optimizers, see [Residential Smart PV Solution Quick Guide \(Single-Phase PV+ESS Scenario + SmartGuard Networking\)](#).

Connection Test

Connection Test is supported in quick settings. You can perform this step to check whether the cable connections are correct, avoiding site visits for rectification.

Choose **Quick Settings > System check > Connection Test**, tap **Start test**, and wait until the test is completed. If the test fails, rectify the fault promptly.

3.5 Parameter Settings

3.5.1 Whole-House Power Backup Settings (Seamless Switchover)

Connect to the SmartAssistant. On the home screen, choose **Set > Power Backup Settings**, enable **Seamless switchover**, and set other parameters.

CAUTION

- The seamless switching function of the SmartGuard needs to be manually enabled. If the function is enabled, the system will switch to off-grid mode within 20 ms after the grid fails or becomes abnormal, ensuring uninterrupted power supply to IT equipment such as computers connected to the backup load port.
- The seamless switching function of the SmartGuard can be used to switch from on-grid mode to off-grid mode or from generator off-grid mode to inverter off-grid mode.

Table 3-7 Parameters for whole-house power backup settings

Parameter	Value Range	Description
Seamless switchover	Disabled (default)	<ul style="list-style-type: none">• When the grid fails, loads will be powered off for a short while during on/off-grid switchover.• The SmartGuard slowly switches to off-grid mode.
	Enabled	<ul style="list-style-type: none">• When the grid fails or is abnormal, the system switches to off-grid mode within 20 ms.• The low voltage ride-through (LVRT) function does not take effect.

Parameter	Value Range	Description
Consider Mains to Be Faulty If (optional)	<ul style="list-style-type: none"> Open (default) Closed 	<p>This parameter can be set only if an ATS is installed.</p> <ul style="list-style-type: none"> Open: When the grid is connected, the circuit for the position feedback signal upon grid connection has low impedance. When the grid is disconnected, the circuit has high impedance. Closed: When the grid is connected, the circuit for the position feedback signal upon grid connection has high impedance. When the grid is disconnected, the circuit has low impedance.
Backup Time Warning Threshold (min)	5-60	Warning of battery backup time in off-grid scenarios.

Figure 3-2 Whole-house power backup settings

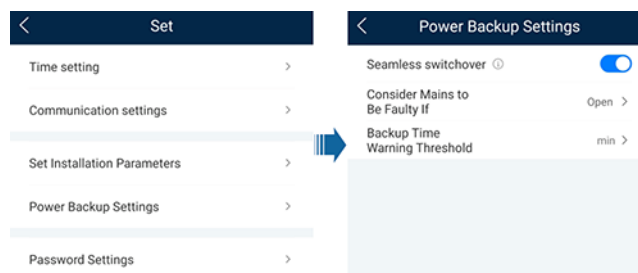

3.5.2 Setting Off-Grid Mode for the Inverter

After the off-grid mode is set, the inverter supports off-grid operation.

Method 1: Setting Off-Grid Mode for the Inverter Using the SmartGuard

Connect to the SmartAssistant. On the home screen, choose **Monitoring > Inverter**, tap **Set > Feature parameters**, and enable **Off-grid mode**.

Figure 3-3 Setting off-grid mode

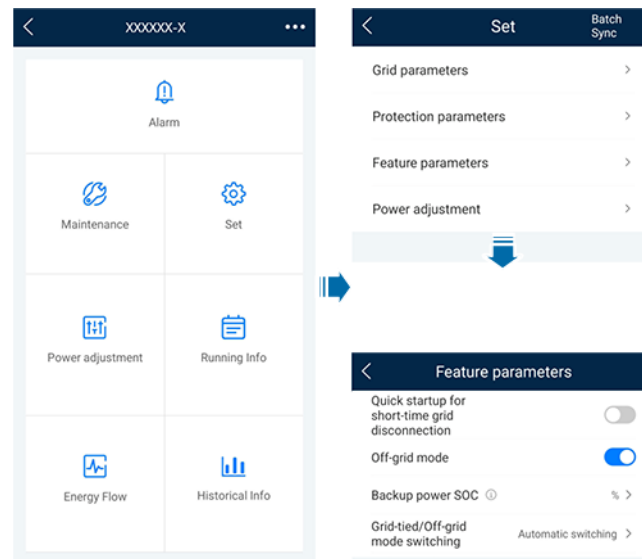

Method 2: Setting the Off-Grid Mode and SmartGuard Model for the Inverter

Connect to the inverter by referring to [A Connecting to the Inverter on the App](#). On the home screen, choose **Set** > **Feature parameters** and enable **Off-grid mode**. If the system is powered on for the first time in off-grid mode, **Backup Box model** must be set to **SmartGuard**. Otherwise, the system will not work.

Table 3-8 On/Off-grid parameter settings

Parameter	Description	Value Range
Off-grid mode	If this parameter is enabled, the inverter switches to off-grid mode through the SmartGuard when the grid fails.	<ul style="list-style-type: none"> Enabled Disabled
Backup power SOC	Set the backup power SOC. In on-grid mode, the ESS stops discharging energy to loads when its SOC reaches the backup power SOC and discharges energy to keep the system running only when there is no irradiance. When the grid fails, the ESS supplies power to loads in backup mode.	[0, 100%]
Backup Box model	SmartGuard must be selected when the system is powered on in off-grid mode. Otherwise, the system will not work.	<ul style="list-style-type: none"> BackupBox-B0/B1 Compatible Third Party BackupBox SmartGuard No BackupBox

3.5.3 (Optional) Setting the External WLAN Antenna

CAUTION

An external WLAN antenna needs to be purchased from Huawei. To use the external WLAN antenna, set **Selected antenna** to **External signal**.

B Connecting to the SmartAssistant on the App. On the home screen, choose **Set > Communication settings > Inverter WLAN settings**, and select **Selected antenna** to **External**.

Figure 3-4 Setting the external antenna

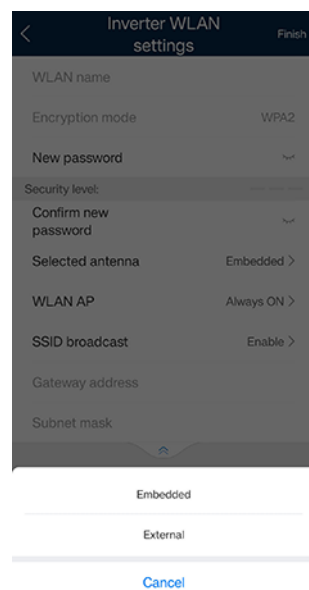

3.5.4 Generator Settings

Setting the Generator Control Mode

Connect to the SmartAssistant. On the home screen, choose **Monitor > SmartDG > Maintenance**, and set the generator control mode to **Automatic**.

Figure 3-5 Setting the generator control mode

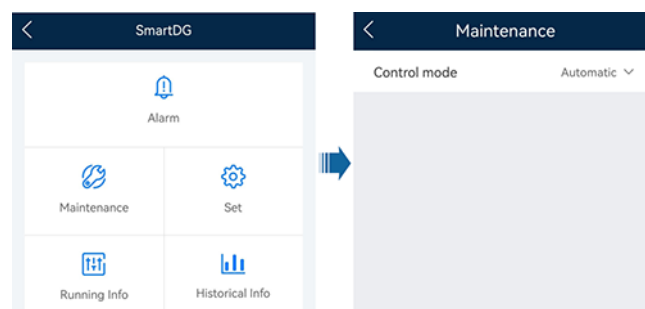

Table 3-9 Generator control parameters

Parameter	Value	Description
Control mode	Manual	<ul style="list-style-type: none"> ● Shut Down ● Power-on
	Automatic	You can set the battery SOC upper and lower thresholds. When the battery SOC reaches the specified upper or lower threshold, the generator automatically shuts down or starts.

Setting Generator Parameters

Connect to the SmartAssistant. On the home screen, choose **Monitor** > **SmartDG** > **Set**, and set generator parameters.

Figure 3-6 Setting generator parameters

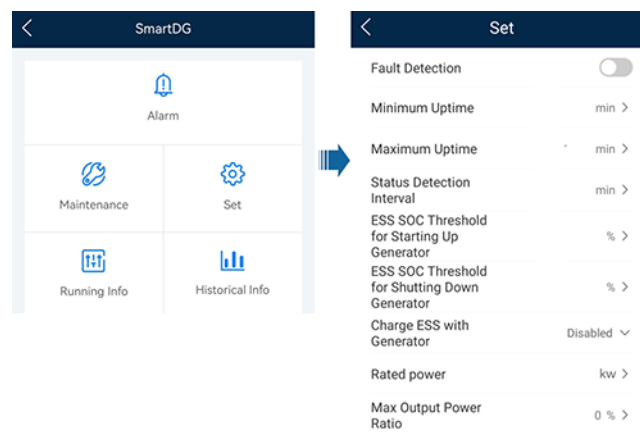
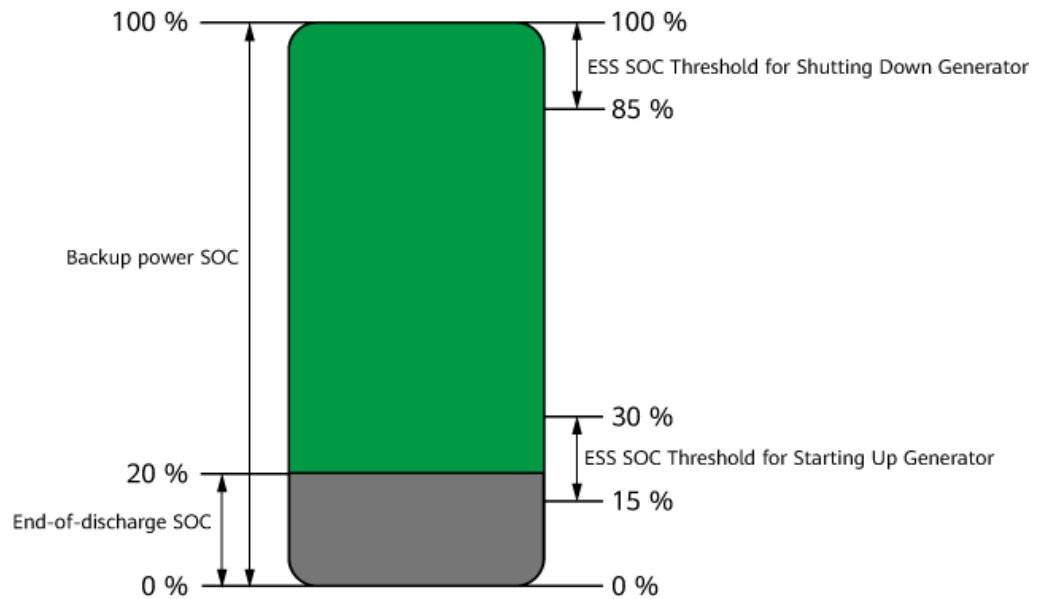

Table 3-10 Generator parameters

Parameter	Value Range	Description
Fault Detection	<ul style="list-style-type: none"> ● Enabled ● Disabled (default) 	After Fault Detection is enabled, you need to set Fault Detection Mode .
Fault Detection Mode	<ul style="list-style-type: none"> ● By ON signal (default) ● By OFF signal 	<ul style="list-style-type: none"> ● By ON signal: When the generator fails to run, the generator alarm signal circuit has low impedance. When the generator is normal, the generator alarm signal circuit has high impedance. ● By OFF signal: When the generator fails to run, the generator alarm signal circuit has high impedance. When the generator is normal, the generator alarm signal circuit has low impedance.

Parameter	Value Range	Description
Minimum Uptime (min)	0-60	In auto control mode, the generator cannot automatically shut down if the specified minimum uptime is not reached.
Maximum Uptime (min)	60-2880	In auto control mode, the generator automatically shuts down upon reaching the specified maximum uptime.
Status Detection Interval (min)	1-10	After the generator startup or shutdown command is delivered, if the generator fails to start or shut down when Status Detection Interval is reached, a generator startup or shutdown failure alarm is reported.
ESS SOC Threshold for Starting Up Generator (%)	15-30	<p>When the battery SOC is lower than ESS SOC Threshold for Starting Up Generator, the generator starts.</p> <ul style="list-style-type: none"> • ESS SOC Threshold for Starting Up Generator \geq End-of-discharge SOC + 10% (For example, if End-of-discharge SOC is 15%, set ESS SOC Threshold for Starting Up Generator to 25% or higher.) • If the generator startup fails, loads will be powered off after the ESS discharges to End-of-discharge SOC. • For details about how to set End-of-discharge SOC for the ESS, see 6.4.2 Setting ESS Parameters in the ESS user manual.
ESS SOC Threshold for Shutting Down Generator (%)	85-100	When the battery SOC is higher than ESS SOC Threshold for Shutting Down Generator , the generator shuts down.
Charge ESS with Generator	<ul style="list-style-type: none"> • Disabled (default) • Enabled 	After this function is enabled, the generator is allowed to charge the ESS.
Rated power (kW)	1-500	Indicates the rated power of the generator.
Max Output Power Ratio (%)	0-100	Indicates the maximum output power ratio of the generator.

Figure 3-7 Battery SOC



3.5.5 Other Parameter Settings

For details about grid connection point parameters, ESS control, demand limit, and optimizer physical layout, see [Parameter Settings](#).

3.6 System Power-Off

Precautions

⚠ WARNING

- Before opening the maintenance compartment door, turn off the main circuit breaker, and then turn off the switches for residential backup loads and non-backup loads. Shut down the inverter, and turn off the DC switches of the inverter and ESS.
 - Only authorized personnel can open the maintenance compartment cover to perform electrical connections.
 - Before opening the maintenance compartment cover, turn off the backup load circuit breaker, grid AC circuit breaker, and two inverter AC circuit breakers inside the SmartGuard.
 - After the SmartGuard powers off, the remaining electricity and heat may still cause electric shocks and burns. Therefore, wait for at least 5 minutes and wear insulated gloves before working on the SmartGuard.
-

Procedure

Step 1 (Optional) On the generator control panel, manually shut down the generator.

Step 2 Turn off the main circuit breaker.

Step 3 Power off the inverter.

1. Send a shutdown command to the inverter on the app.
2. Set the **DC SWITCH** of the inverter to **OFF**.
3. (Optional) Install the locking screw for the **DC SWITCH**.
4. (Optional) Turn off the DC switch between the inverter and PV strings.

Step 4 Shut down the ESS.

1. Set the **DC SWITCH** of the ESS to **OFF**.
2. (Optional) Install the locking screw for the **DC SWITCH** of the ESS.

Step 5 Turn off the switches for residential backup loads and non-backup loads.

----**End**

4 Three-Phase SmartGuard Networking

4.1 Networking Application

CAUTION

- If the power of backup loads exceeds the maximum off-grid power of the system, the inverter may be shut down due to overload. In this case, you need to shut down some loads. Alternatively, connect loads with lower priority to the non-backup load port.
- If the generator deployed in the power plant runs in off-grid mode and the load power exceeds the generator capacity, the generator may shut down due to overload. You are advised to shut down some loads.
- If the main circuit breaker's rating is 63 A or less, you can connect all or some of the loads to the SmartGuard. However, if the rating is greater than 63 A, you can connect only some of the loads to the SmartGuard.
- TN-C system: No residual current device (RCD) is required.

Step 1 Residential load classification (dashed boxes indicate optional components)

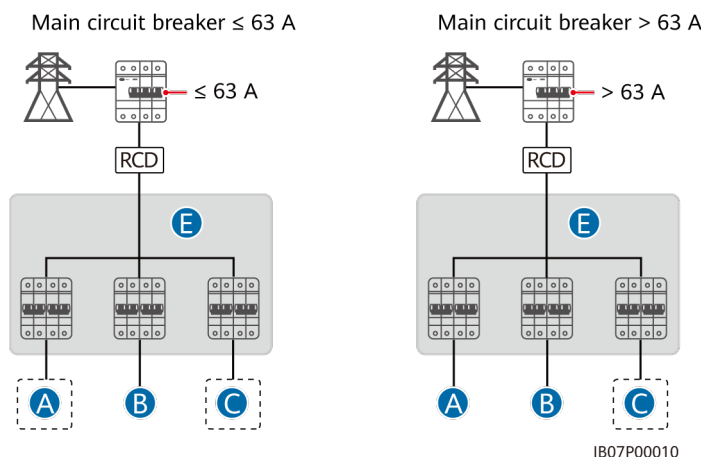

Main Circuit Breaker	Connect All Loads to the SmartGuard	Connect Some of Loads to the SmartGuard
≤ 63 A	Supported	Supported
> 63 A	Not supported	Supported

Step 2 Classification of loads connected to the SmartGuard (dashed boxes indicate optional components)

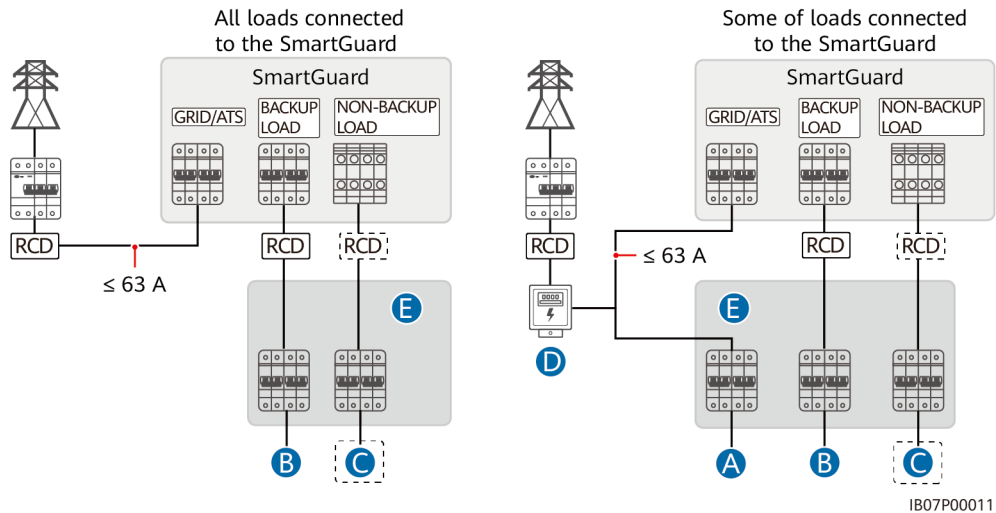

- (A) Load not connected to the SmartGuard (B) Backup load (C) Non-backup load
(D) Power meter (E) AC power distribution box

----End

4.1.1 On/Off-Grid PV+ESS Scenario

 **DANGER**

- TN-S/TN-C-S/TT system: An RCD must be installed before the backup load. During off-grid operation, the main circuit breaker does not provide protection. Electric leakage on the loads may result in electric shocks. The rated voltage of the RCD must be at least 415 V AC. Its rated residual operating current must be \geq Number of M1 or MAP0 inverters x 100 mA or \geq Number of MB0 inverters x 300 mA.
- TN-S/TN-C-S/TT system: A main circuit breaker with the leakage protection function must be installed. Its rated voltage must be at least 415 V AC. Its rated residual operating current must be \geq Number of M1 or MAP0 inverters x 100 mA or \geq Number of MB0 inverters x 300 mA.
- TN-C system: No residual current device (RCD) is required.
- A maximum of three MAP0 inverters can be connected in parallel. If two MAP0 inverters need to connect to the same port, connect them in parallel first.

 **NOTE**

- The SmartAssistant in the SmartGuard can be connected to the router over FE or WLAN. If WLAN is used, the SmartGuard must be installed close to the router.
- Both the SmartAssistant in the SmartGuard and the Smart Dongle provide communication capabilities. Only either of them can be installed in a power plant for networking. Otherwise, communication between devices will be abnormal.
- It is recommended that the charger and the SmartAssistant in the SmartGuard be connected to the router in wired network (FE) mode. If the charger is connected to the router in WLAN mode, the communication may be interrupted due to unstable signals.
- The three-phase SmartGuard supports a maximum load current of 63 A. If the load current exceeds 63 A, only some of loads can be connected to it. In addition, a power meter needs to be connected between the three-phase SmartGuard and the main circuit breaker.

Table 4-1 System configuration with the LUNA2000-(5-30)-S0

Inverter	LUNA2000-(5-30)-S0	SmartGuard AC Port to Be Connected	Max. Number of Connected ESSs
SUN2000-(5KTL-12KTL)-M1	√	INV2	2
SUN2000-(12K-25K)-MB0	√	INV1	4
SUN5000-(17K, 25K)-MB0	√	INV1	4
SUN2000-(5K-12K)-MAP0	√	INV2	2
SUN5000-(8K, 12K)-MAP0	√	INV2	2

Table 4-2 System configuration with the LUNA2000-S1

Inverter	LUNA2000-S1	SmartGuard AC Port to Be Connected	Max. Number of Connected ESSs
SUN2000-(5KTL-12KTL)-M1	√	INV2	2
SUN2000-(12K-25K)-MB0	√	INV1	4
SUN5000-(17K, 25K)-MB0	√	INV1	4
SUN2000-(5K-12K)-MAP0	√	INV2	2
SUN5000-(8K, 12K)-MAP0	√	INV2	2

Parallel Inverters

Figure 4-3 Connecting all loads to the SmartGuard

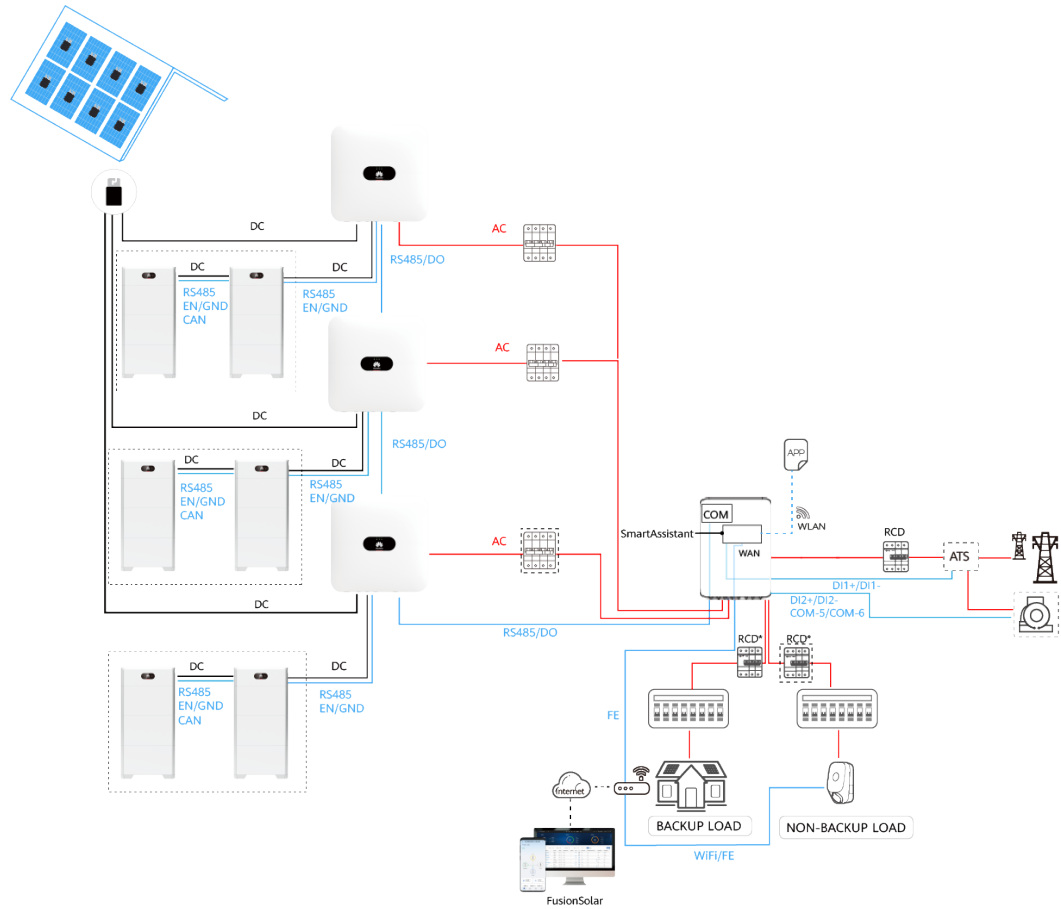

Figure 4-4 Connecting some of loads to the SmartGuard

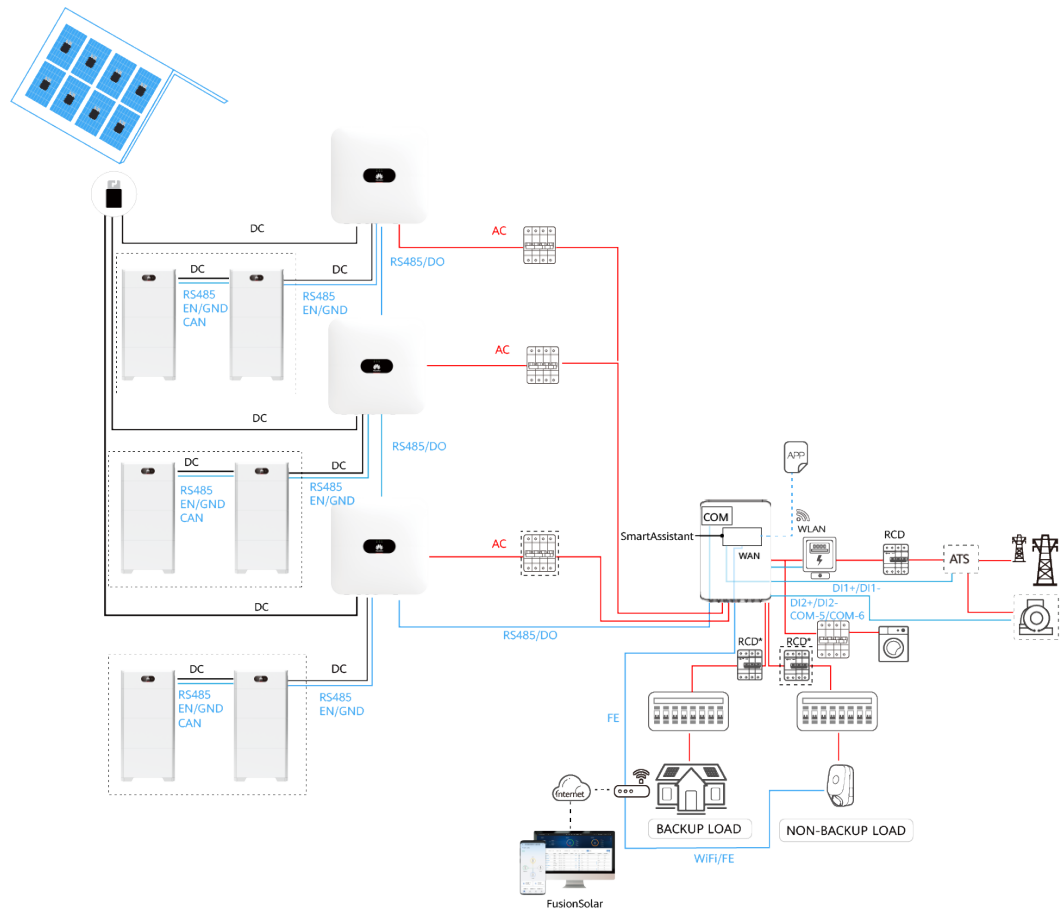

Table 4-3 Inverter combination and quantity restriction

Inverter Combination	Max. Number of Parallel Inverters
MAP0+MAP0	3
M1+MAP0	One M1 and a maximum of two MAP0s. The power of inverters installed must meet the power requirements of the INV1 and INV2 ports on the SmartGuard.
M5+MAP0	One M5 and a maximum of two MAP0s. The power of inverters installed must meet the power requirements of the INV1 and INV2 ports on the SmartGuard.

Inverter Combination	Max. Number of Parallel Inverters
MB0+MAP0	One MB0 and a maximum of two MAP0s. The power of inverters installed must meet the power requirements of the INV1 and INV2 ports on the SmartGuard.
<p>Note:</p> <ul style="list-style-type: none"> • When the M1, M5, or MB0 is connected to the MAP0 in parallel, the L1, L2, L3, and N wires of the M1, M5, or MB0 must be connected. • In off-grid state, only the MAP0 runs off-grid, and the M1, M5, or MB0 does not output AC power. If an ESS and PV power are available, the M1 or MB0 can charge the ESS. • When the MAP0 is connected to the M1, M5, or MB0 in parallel, the MAP0 does not support three-phase imbalance control, and the off-grid mode of the M1, M5, or MB0 does not take effect. • Diesel generators are not supported when the M1, M5, or MB0 is connected to the MAP0 in parallel. • When the M1, M5, or MB0 is connected to the MAP0 in parallel, only the MAP0 can be used for off-grid deployment. 	

The current of inverters connected to the INV1 port on the SmartGuard cannot exceed 40 A. The current of inverters connected to the INV2 port on the SmartGuard cannot exceed 20 A. The total current of inverters connected to the INV1 and INV2 ports on the SmartGuard cannot exceed 60 A.

The current at the output port of an inverter can be calculated according to the inverter power and grid voltage. Assume that the voltage is 230 V and the current at the output port of a 12 kW inverter is $12000 \text{ W} \times 1.1/3/230 \text{ V} = 19.1 \text{ A}$. Then, the 12 kW inverter can be connected to the INV2 port of the SmartGuard.

Figure 4-5 M1, M5, or MB0 connected to the MAP0 in parallel (dashed boxes indicating optional components)

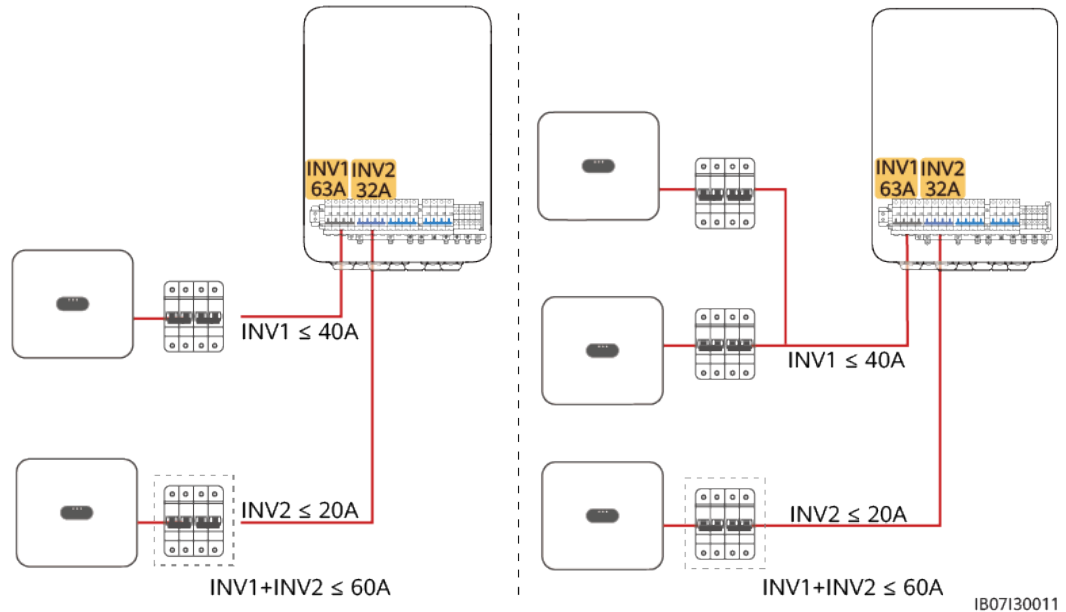

Table 4-4 Version requirements for connecting the M1, M5, or MB0 to the MAP0 in parallel

Device	Version
SUN2000-(12KTL-25KTL)-M5	SUN2000MB V200R023C10SPC213 or later
SUN2000-(5KTL-12KTL)-M1	SUN2000MA V100R001C00SPC174 or later
SUN2000-10KTL-BEM1	SUN2000MA V100R001C00SPC174 or later
SUN2000-(12K-25K)-MB0	SUN2000MB V200R023C10SPC213 or later
SUN2000-(5K-12K)-MAP0	SUN2000MA V200R024C00SPC108 or later
SmartAssistant	SmartHEMS V100R025C00SPC120 or later
SmartGuard	BackupBoxA V100R024C00SPC103
FusionSolar app	25.4.100 or later
FusionSolar SmartPVMS	SmartPVMS 25.3.0.5 or later

Commissioning Procedure for the Scenario Where the M1, M5, or MB0 Is Connected to the MAP0 in Parallel (On-Grid)

NOTE

In new deployment scenarios, skip the steps of device removal, data migration, and meter deletion.

- Step 1** Before connecting an existing M1, M5, or MB0 to the MAP0 in parallel, locally connect the FusionSolar app to the M1, M5, or MB0 and upgrade the M1, M5, or MB0 software version.
- Step 2** Send a shutdown command on the app to the M1, M5, or MB0.
- Step 3** Power off the system.
1. Turn off the main circuit breaker and set the **DC SWITCH** on the inverter to **OFF**.
 2. (Optional) Turn off the ESS: Set the **DC SWITCH** on the ESS to **OFF**.
 3. Turn off the home load switch.
- Step 4** Remove the Smart Dongle and meter, and connect all inverter, SmartGuard, and ESS cables.
- Step 5** Turn on the main circuit breaker and power on the system in on-grid mode.
1. (Optional) Turn on the ESS: Set the **DC SWITCH** on the ESS to **ON**.
 2. Power on the inverter: Set the **DC SWITCH** on the inverter to **ON**.
- Step 6** Power on the loads. After checking that the residential load circuit is not short-circuited, turn on the backup load and non-backup load switches.
- Step 7** Connect the app to the SmartAssistant locally, go to the **Quick Settings** screen, complete plant deployment, and connect to the existing plant.

NOTICE

During the version check phase in quick settings, upgrade the software version of the SmartAssistant, SmartGuard, and MAP0 as prompted on the app. Otherwise, the system cannot run properly.

- Step 8** Send a startup command on the app to the M1, M5, or MB0.
- Step 9** On the app, set **Output mode** under **Grid parameters** to **Three-phase, four-wire** for the M1, M5, or MB0.
- Step 10** Migrate data by referring to [Data Migration](#), and then delete the meter by referring to [Deleting an Offline Device](#).

----End

Commissioning Procedure for the Scenario Where the M1, M5, or MB0 Is Connected to the MAP0 in Parallel (Off-Grid)

 **NOTE**

In new deployment scenarios, skip the steps of device removal, data migration, and meter deletion.

- Step 1** Before connecting an existing M1, M5, or MB0 to the MAP0 in parallel, locally connect the FusionSolar app to the M1, M5, or MB0 and upgrade the M1, M5, or MB0 software version.
- Step 2** Send a shutdown command on the app to the M1, M5, or MB0.

Step 3 Power off the system.

1. Turn off the main circuit breaker and set the **DC SWITCH** on the inverter to **OFF**.
2. (Optional) Turn off the ESS: Set the **DC SWITCH** on the ESS to **OFF**.
3. Turn off the home load switch.

Step 4 Remove the Smart Dongle and meter, and connect all inverter, SmartGuard, and ESS cables.

Step 5 Power on the DC side of the MAP0: Set the **DC SWITCH** on the MAP0 to **ON**.

- If PV power is available, set the **DC SWITCH** on the ESS to **ON**.
- If PV power is unavailable, set the **DC SWITCH** on the ESS to **ON** and hold down the black start button for 5s.

Step 6 Connect the app to the MAP0 locally. On the home screen, choose **Settings > Grid parameters** and set the grid code. Choose **Feature parameters** and enable **Off-grid mode**.

If the system is powered on for the first time in off-grid mode, **Backup Box model** must be set to **SmartGuard**. Otherwise, the system will not work.

Table 4-5 On/Off-grid parameter settings

Parameter	Description	Value Range
Off-grid mode	If this parameter is enabled, the inverter switches to off-grid mode through the SmartGuard when the grid fails.	<ul style="list-style-type: none"> • Enabled • Disabled
Backup power SOC	Set the backup power SOC. In on-grid mode, the ESS stops discharging energy to loads when its SOC reaches the backup power SOC and discharges energy to keep the system running only when there is no irradiance. When the grid fails, the ESS supplies power to loads in backup mode.	[0, 100%]
Backup Box model	SmartGuard must be selected when the system is powered on in off-grid mode. Otherwise, the system will not work.	<ul style="list-style-type: none"> • BackupBox-(B0,B1) • Compatible Third Party BackupBox • SmartGuard • No Backup Box

Step 7 Observe LED1 and LED2 on the MAP0. If the two indicators are steady yellow, the MAP0 is running properly in off-grid state.

Step 8 Set the **DC SWITCH** on the M1, M5, or MB0 to **ON**.

Step 9 Connect the app to the SmartAssistant locally, go to the **Quick Settings** screen, complete plant deployment, and connect to the existing plant.

NOTICE

During the version check phase in quick settings, upgrade the software versions of the SmartAssistant, SmartGuard, and MAPO as prompted on the app. In off-grid mode, only the SmartAssistant can be upgraded. The SmartGuard and MAPO can be upgraded only after the power grid recovers.

Once the MAPO is upgraded, the system powers off and restarts.

Step 10 Send a startup command on the app to the M1, M5, or MB0.

CAUTION

You can send a startup command on the app to the M1, M5, or MB0 only after the plant deployment is complete. Otherwise, the system may not run properly.

Step 11 On the app, set **Output mode** under **Grid parameters** to **Three-phase, four-wire** for the M1, M5, or MB0.

Step 12 Migrate data by referring to [Data Migration](#), and then delete the meter by referring to [Deleting an Offline Device](#).

Step 13 Power on the loads. After checking that the residential load circuit is not short-circuited, turn on the backup load and non-backup load switches.

Step 14 Turn on the main circuit breaker.

----End

NOTE

- The LUNA2000-(5-30)-S0 and LUNA2000-S1 cannot connect to the same inverter in a parallel system.
- If inverters are cascaded, the LUNA2000-(5-30)-S0 and LUNA2000-S1 can be connected to different inverters.

4.2 Electrical Connections

For details about cable connections in typical scenarios, see the following table.

Table 4-6 Three-phase PV+ESS system + SmartGuard networking

Cable Connection Scenario	Documentation
Three-phase inverter + LUNA2000-(5-30)-S0 + SmartGuard-63A-T0/AUT0	Residential Smart PV Solution Quick Guide (Three-Phase PV+ESS Scenario + SmartGuard Networking)
Three-phase inverter + LUNA2000-(7, 14, 21)-S1 + SmartGuard-63A-T0/AUT0	

4.3 System Power-On

4.3.1 Method 1: Power-On in On-Grid Mode or by Starting the Generator

Precautions

DANGER

- Wear personal protective equipment and use dedicated insulated tools to avoid electric shocks or short circuits.
-

NOTICE

Before the equipment is put into operation for the first time, ensure that the parameters are set correctly by professional personnel. Incorrect parameter settings may result in noncompliance with local grid connection requirements and affect the normal operations of the equipment.

4.3.1.1 Powering On the SmartGuard

NOTICE

- If the high-power load configured for the power plant is connected to the non-backup port of the SmartGuard or is connected outside the SmartGuard, choose power-on in on-grid mode for device commissioning when the power plant is powered on for the first time. If you choose power-on in off-grid mode, the high-power load cannot be detected because it is not powered on during device commissioning.
 - If some of loads in the power plant are connected to the SmartGuard, choose power-on in on-grid mode or by starting the generator for device commissioning when the plant is powered on for the first time. If you choose power-on in off-grid mode, the external power meter cannot be detected during device commissioning because it is not powered on.
 - If the PV strings are equipped with optimizers, power on the system in on-grid mode or by starting the generator.
 - During power-on and commissioning, ignore the alarm indicating that the bypass switch is on.
-

Method 1: Power-On in On-Grid Mode

- Step 1** Use a multimeter to check that the AC voltage in the power distribution box is within the allowed range and that cables are correctly connected.

Step 2 Turn on the main circuit breaker.

Step 3 Turn on the ESS switch.

1. (Optional) Remove the locking screw for the **DC SWITCH** of the ESS.
2. Set the **DC SWITCH** of the ESS to ON.

Step 4 Power on the inverter.

1. (Optional) Turn on the DC switch (if any) between the PV strings and the inverter.
2. (Optional) Remove the locking screw for the **DC SWITCH** of the inverter.
3. Set the **DC SWITCH** of the inverter to ON.

Step 5 Check that the SmartGuard is running in on-grid mode. Observe the LED indicators on the inverter, ESS, SmartAssistant, and SmartGuard to check the running status.

----End

Method 2: Power-On by Starting the Generator

NOTE

During system upgrade, manually start the generator on the generator control panel to prevent upgrade failures caused by generator shutdown.

Step 1 On the control panel of the generator, manually start the generator. Use a multimeter to check that the AC voltage in the power distribution box is within the allowed range and that cables are correctly connected.

Step 2 Turn on the main circuit breaker.

Step 3 Turn on the ESS switch.

1. (Optional) Remove the locking screw for the **DC SWITCH** of the ESS.
2. Set the **DC SWITCH** of the ESS to ON.

Step 4 Power on the inverter.

1. (Optional) Turn on the DC switch (if any) between the PV strings and the inverter.
2. (Optional) Remove the locking screw for the **DC SWITCH** of the inverter.
3. Set the **DC SWITCH** of the inverter to ON.

Step 5 Check that the SmartGuard is running in on-grid mode. Observe the LED indicators on the inverter, ESS, SmartAssistant, and SmartGuard to check the running status.

----End

LED Indicators on the SmartAssistant and SmartGuard

Table 4-7 SmartAssistant indicator description





Indicator	Status	Description
Running status indicator 	Off	The system is not powered on.
	Steady green	The system is powered on and running.
Alarm indicator 	Off	No alarm is raised.
	Blinking red slowly (on for 1s and then off for 4s)	The system raises a warning.
	Blinking red fast (on for 0.5s and then off for 0.5s)	The system raises a minor alarm.
	Steady red	The system raises an urgent/critical alarm.
Communication status indicator 	Off	The IP address of the management system server is not configured. (The indicator is off when the SmartAssistant is not connected to the FusionSolar SmartPVMS.)
	Blinking green slowly (on for 1s and then off for 1s)	The communication with the management system is normal.
	Blinking green fast (on for 0.125s and then off for 0.125s)	The communication with the management system is interrupted.

Table 4-8 Indicators on the SmartGuard

Indicator	Status	Description
	Steady green	The SmartGuard is in on-grid mode.
	Blinking green slowly	The SmartGuard is in generator off-grid mode.
	Steady orange	The SmartGuard is in inverter off-grid mode.

Indicator	Status	Description
	Steady red	A hardware alarm is generated on the SmartGuard.
	Blinking red slowly	An environment alarm is generated on the SmartGuard.

4.3.1.2 Powering On Loads

- Step 1** Check that the inverter, ESS, SmartAssistant, and SmartGuard are working properly in on-grid mode.
- Step 2** (Optional) Turn off switches for high-power home appliances to avoid generator overload.
- Step 3** After checking that the residential load circuit is not short-circuited, turn on the backup load and non-backup load switches. Otherwise, the SmartGuard may be damaged.
- Step 4** (Optional) Set Huawei charger route parameters.
- Step 5** Commission the device. For details, see [4.5 Parameter Settings](#).
- Step 6** After the commissioning is complete, turn off the bypass switch. Otherwise, the system cannot run properly. For details, see [4.3.1.3 Turning Off the Bypass Switch](#).

----End

4.3.1.3 Turning Off the Bypass Switch

 **DANGER**

- During normal use, do not operate the bypass switch and ensure that it is off.
 - Do not turn on the bypass switch when the power is on. Otherwise, the high voltage may result in electric shocks and damage to the equipment.
 - If the bypass switch latch is not installed, the bypass switch may be misoperated, which may cause high-voltage electric shocks and damage to the equipment.
-

- Step 1** Power off the system and open the maintenance compartment door.
- Step 2** Turn off the bypass switch and install the bypass switch latch.

Figure 4-6 Turning off the bypass switch

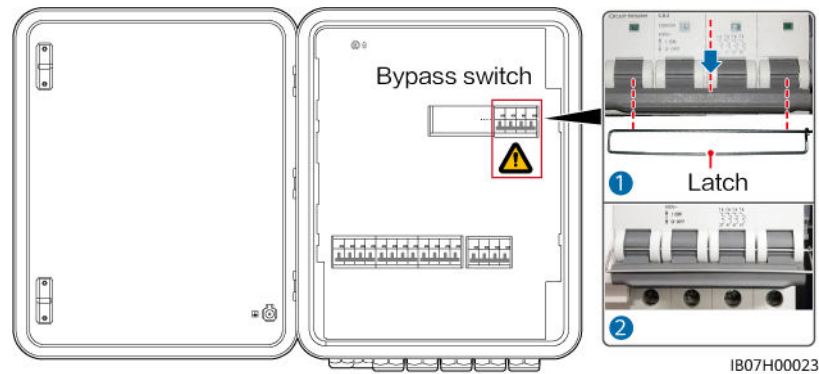

Step 3 Close the maintenance compartment door and power on the system.

----End

4.3.2 Method 2: Power-On in Off-Grid Mode

Precautions

DANGER

- Wear personal protective equipment and use dedicated insulated tools to avoid electric shocks or short circuits.
-

NOTICE

Before the equipment is put into operation for the first time, ensure that the parameters are set correctly by professional personnel. Incorrect parameter settings may result in noncompliance with local grid connection requirements and affect the normal operations of the equipment.

4.3.2.1 Powering On the SmartGuard

NOTICE

- If the high-power load configured for the power plant is connected to the non-backup load port of the SmartGuard or is connected outside the SmartGuard, choose power-on in on-grid mode for device commissioning when the power plant is powered on for the first time. If you choose power-on in off-grid mode, the high-power load cannot be detected because it is not powered on during device commissioning.
- If some of loads in the power plant are connected to the SmartGuard, choose power-on in on-grid mode or by starting the generator for device commissioning when the plant is powered on for the first time. If you choose power-on in off-grid mode, the external power meter cannot be detected during device commissioning because it is not powered on.
- If the PV strings are equipped with optimizers, power-on in off-grid mode is not supported.

Power-On in Off-Grid Mode

Step 1 Keep the main circuit breaker off.

Step 2 Power on the inverter.

1. (Optional) Turn on the DC switch (if any) between the PV strings and the inverter.
2. (Optional) Remove the knob locking screw for the **DC SWITCH** of the inverter.
3. Set the **DC SWITCH** of the inverter to ON.

Step 3 Turn on the ESS switch.

1. (Optional) Remove the locking screw for the **DC SWITCH** of the ESS.
2. Set the **DC SWITCH** of the ESS to ON.
3. Press and hold the black start button for 5s.

Step 4 Connect to the inverter by referring to [A Connecting to the Inverter on the App](#), set the grid code for the inverter, and then set the off-grid mode and SmartGuard model for the inverter. For details, see [Method 2: Setting the Off-Grid Mode and SmartGuard Model for the Inverter](#).

Step 5 (Optional) Connect to the inverter by referring to [A Connecting to the Inverter on the App](#). Upgrade the M1 and MB0 inverters to the latest version. Otherwise, the SmartGuard may fail to identify the inverters. For details, see [D Upgrading the Inverter](#).

Step 6 Check that the SmartGuard is running in off-grid mode. Observe the LED indicators on the inverter, ESS, SmartAssistant, and SmartGuard to check the running status.

----End

LED Indicators on the SmartAssistant and SmartGuard

Table 4-9 SmartAssistant indicator description





Indicator	Status	Description
Running status indicator 	Off	The system is not powered on.
	Steady green	The system is powered on and running.
Alarm indicator 	Off	No alarm is raised.
	Blinking red slowly (on for 1s and then off for 4s)	The system raises a warning.
	Blinking red fast (on for 0.5s and then off for 0.5s)	The system raises a minor alarm.
	Steady red	The system raises an urgent/critical alarm.
Communication status indicator 	Off	The IP address of the management system server is not configured. (The indicator is off when the SmartAssistant is not connected to the FusionSolar SmartPVMS.)
	Blinking green slowly (on for 1s and then off for 1s)	The communication with the management system is normal.
	Blinking green fast (on for 0.125s and then off for 0.125s)	The communication with the management system is interrupted.

Table 4-10 Indicators on the SmartGuard

Indicator	Status	Description
	Steady green	The SmartGuard is in on-grid mode.
	Blinking green slowly	The SmartGuard is in generator off-grid mode.
	Steady orange	The SmartGuard is in inverter off-grid mode.

Indicator	Status	Description
	Steady red	A hardware alarm is generated on the SmartGuard.
	Blinking red slowly	An environment alarm is generated on the SmartGuard.

4.3.2.2 Powering On Loads

⚠ CAUTION

- The power and current of backup loads cannot exceed the maximum off-grid power and current of the system. You are advised to shut down high-power loads and unnecessary loads connected to the backup load port.
- In off-grid mode, if **ESS SOC < End-of-discharge SOC**, the inverter stops output (the backup loads are powered off) and the PV strings charge the battery. The inverter automatically resumes output when the battery SOC reaches **End-of-discharge SOC** plus 20% or higher.

Step 1 Check that the inverter, ESS, SmartAssistant, and SmartGuard are working properly in off-grid mode.

Step 2 Check that the residential backup load power does not exceed the off-grid operating power of the system.

Step 3 After checking that the residential load circuit is not short-circuited, turn on the backup load and non-backup load switches.

----End

4.4 Deploying a New Plant

Figure 4-7 Deploying a new plant

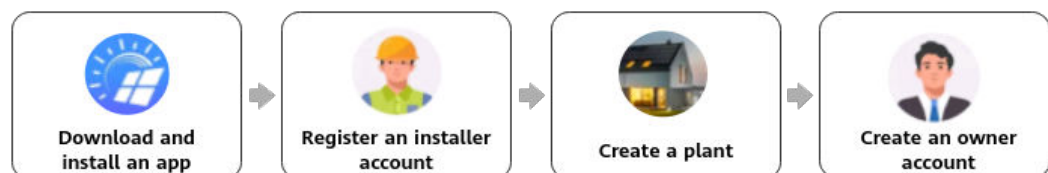

Table 4-11 Plant deployment description

No.	Task	Description
1	Downloading and installing an app	Download and install the FusionSolar app.
2	Registering an installer account	Register an installer account required for deployment and commissioning.
3	Creating a plant	Access the Setup wizard screen, scan the QR code to create a plant, commission devices according to the quick setting process, and connect devices to the plant.
4	Creating an owner account	Create an owner account that can be used to remotely monitor and manage devices.

 **NOTE**

- For details about new plant deployment and existing plant revamping, see [FusionSolar App Quick Guide \(SmartAssistant\)](#) or scan the QR code.
- In the existing plant revamping scenario, the SmartGuard and Dongle cannot be used at the same time. You need to remove the Dongle from the inverter. The SmartGuard has a built-in power meter. If all loads are connected to the SmartGuard, the original power meter in the power plant needs to be directly removed. If some of loads are connected to the SmartGuard, a power meter of the recommended model must be used and its cables need to be reconnected. For details about the cable connections.
- For details about how to set ESS parameters, inverter parameters, and physical layout of optimizers, see [Residential Smart PV Solution Quick Guide \(Three-Phase PV+ESS Scenario + SmartGuard Networking\)](#).
- Before device commissioning, ensure that the router is powered on.

Connection Test

Connection Test is supported in quick settings. You can perform this step to check whether the cable connections are correct, avoiding site visits for rectification.

Choose **Quick Settings** > **System check** > **Connection Test**, tap **Start test**, and wait until the test is completed. If the test fails, rectify the fault promptly.

4.5 Parameter Settings

4.5.1 Whole-House Power Backup Settings (Seamless Switchover)

Connect to the SmartAssistant. On the home screen, choose **Set** > **Power Backup Settings**, enable **Seamless switchover**, and set other parameters.

 **CAUTION**

- The seamless switching function of the SmartGuard needs to be manually enabled. If the function is enabled, the system where an MAPO inverter is installed will switch to off-grid mode within 20 ms after the grid fails or becomes abnormal, ensuring uninterrupted power supply to IT equipment such as computers connected to the backup load port. Other devices may be intermittently disconnected, powered off, or restarted.
- The seamless switching function of the SmartGuard can be used to switch from on-grid mode to off-grid mode or from generator off-grid mode to inverter off-grid mode.

Table 4-12 Parameters for whole-house power backup settings

Parameter	Value Range	Description
Seamless switchover	Disabled (default)	<ul style="list-style-type: none"> • When the grid fails, loads will be powered off for a short while during on/off-grid switching. • The SmartGuard slowly switches to off-grid mode.
	Enabled	<ul style="list-style-type: none"> • When the grid fails or is abnormal, the system where an MAPO inverter is installed switches to off-grid mode within 20 ms. • When the grid fails or is abnormal, the system where an M1 or MBO inverter is installed switches to off-grid mode within 100 ms. • The low voltage ride-through (LVRT) function does not take effect.
Consider Mains to Be Faulty If (optional)	<ul style="list-style-type: none"> • Open (default) • Closed 	<p>This parameter can be set only if an ATS is installed.</p> <ul style="list-style-type: none"> • Open: When the grid is connected, the circuit for the position feedback signal upon grid connection has low impedance. When the grid is disconnected, the circuit has high impedance. • Closed: When the grid is connected, the circuit for the position feedback signal upon grid connection has high impedance. When the grid is disconnected, the circuit has low impedance.
Backup Time Warning Threshold (min)	5–60	Warning of battery backup time in off-grid scenarios.

Parameter	Value Range	Description
Power grid system	<ul style="list-style-type: none"> TN-S/TN-C-S/TT (default) TN-C 	<ul style="list-style-type: none"> Select the correct earthing system based on the actual situation. Ensure that the cable connection mode of the SmartGuard matches the earthing system. If they do not match, an alarm will be generated. If the earthing system is changed, the SmartGuard will restart, causing the backup load to power off.

Figure 4-8 Whole-house power backup settings

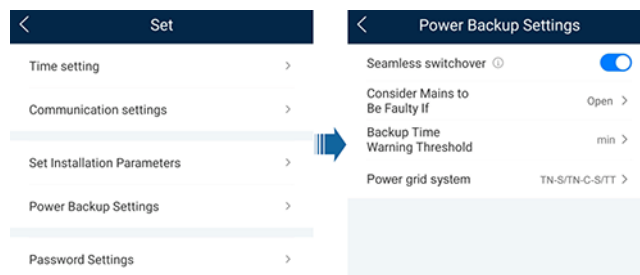

4.5.2 Setting Off-Grid Mode for the Inverter

After the off-grid mode is set, the inverter supports off-grid operation.

Method 1: Setting Off-Grid Mode for the Inverter Using the SmartGuard

B Connecting to the SmartAssistant on the App. On the home screen, choose **Monitor > Inverter**, tap **Set > Feature parameters**, and enable **Off-grid mode**.

Figure 4-9 Setting off-grid mode

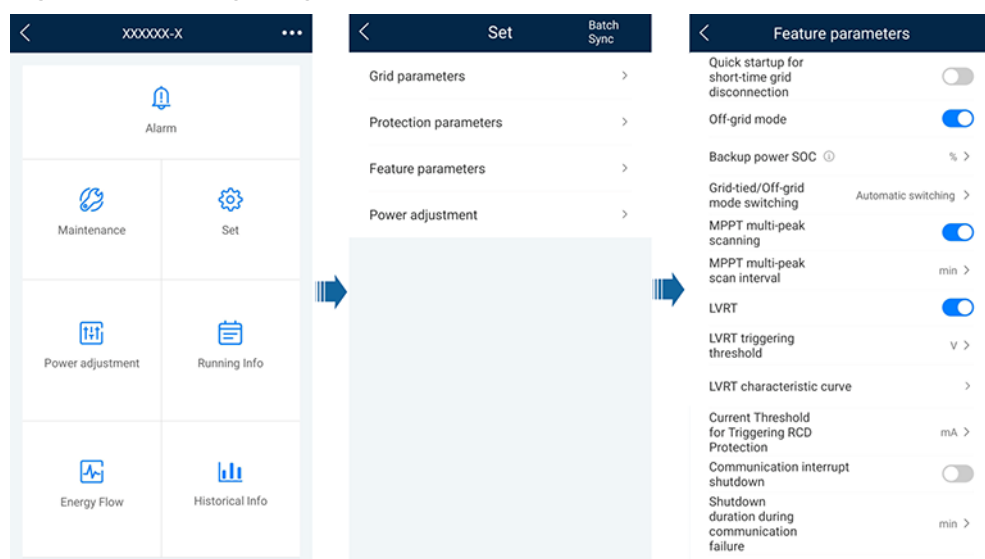

Method 2: Setting the Off-Grid Mode and SmartGuard Model for the Inverter

Connect to the inverter by referring to [A Connecting to the Inverter on the App](#). On the home screen, choose **Set > Feature parameters** and enable **Off-grid mode**. If the system is powered on for the first time in off-grid mode, **Backup Box model** must be set to **SmartGuard**. Otherwise, the system will not work.

Table 4-13 On/Off-grid parameter settings

Parameter	Description	Value Range
Off-grid mode	If this parameter is enabled, the inverter switches to off-grid mode through the SmartGuard when the grid fails.	<ul style="list-style-type: none"> Enabled Disabled
Backup power SOC	Set the backup power SOC. In on-grid mode, the ESS stops discharging energy to loads when its SOC reaches the backup power SOC and discharges energy to keep the system running only when there is no irradiance. When the grid fails, the ESS supplies power to loads in backup mode.	[0, 100%]
Backup Box model	SmartGuard must be selected when the system is powered on in off-grid mode. Otherwise, the system will not work.	<ul style="list-style-type: none"> BackupBox-(B0,B1) Compatible Third Party BackupBox SmartGuard No Backup Box

4.5.3 (Optional) Setting the External WLAN Antenna

 **CAUTION**

An external WLAN antenna needs to be purchased from Huawei. To use the external WLAN antenna, set **Selected antenna** to **External signal**.

B Connecting to the SmartAssistant on the App. On the home screen, choose **Set > Communication settings > Inverter WLAN settings**, and select **Selected antenna** to **External**.

Figure 4-10 Setting the external antenna

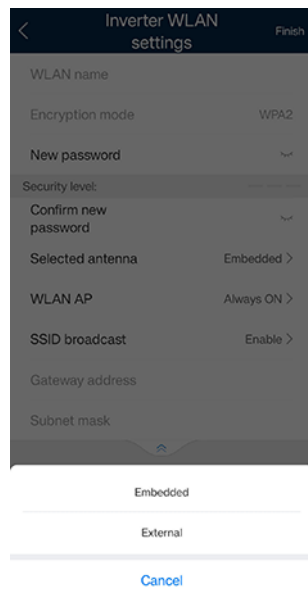

4.5.4 Generator Settings

Setting the Generator Control Mode

Connect to the SmartAssistant. On the home screen, choose **Monitor** > **SmartDG** > **Maintenance**, and set the generator control mode to **Automatic**.

Figure 4-11 Setting the generator control mode

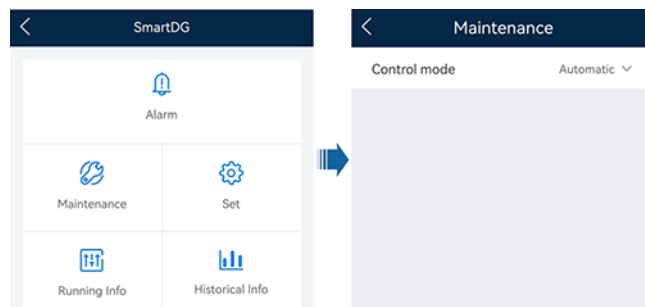

Table 4-14 Generator control parameters

Parameter	Value	Description
Control mode	Manual	<ul style="list-style-type: none"> Shut Down Power-on
	Automatic	You can set the battery SOC upper and lower thresholds. When the battery SOC reaches the specified upper or lower threshold, the generator automatically shuts down or starts.

Setting Generator Parameters

Connect to the SmartAssistant. On the home screen, choose **Monitor > SmartDG > Set**, and set generator parameters.

Figure 4-12 Setting generator parameters

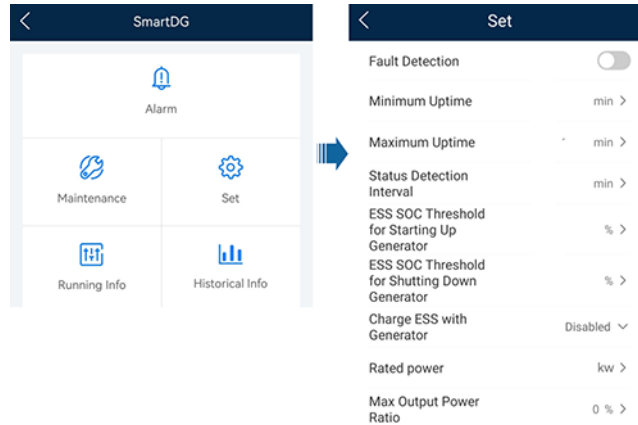
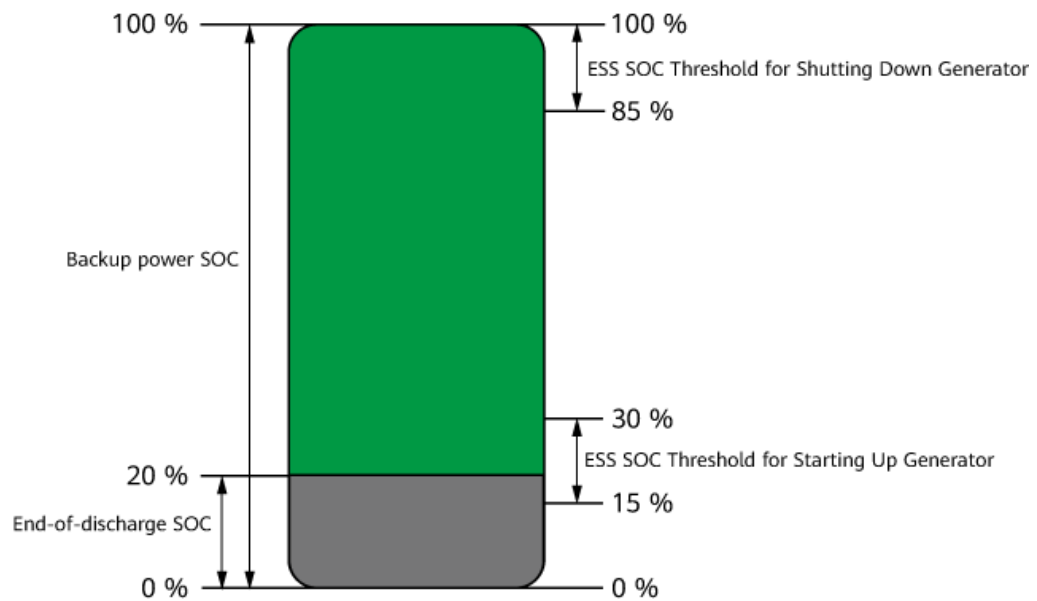

Table 4-15 Generator parameters

Parameter	Value Range	Description
Fault Detection	<ul style="list-style-type: none"> Enabled Disabled (default) 	After Fault Detection is enabled, you need to set Fault Detection Mode .
Fault Detection Mode	<ul style="list-style-type: none"> By ON signal (default) By OFF signal 	<ul style="list-style-type: none"> By ON signal: When the generator fails to run, the generator alarm signal circuit has low impedance. When the generator is normal, the generator alarm signal circuit has high impedance. By OFF signal: When the generator fails to run, the generator alarm signal circuit has high impedance. When the generator is normal, the generator alarm signal circuit has low impedance.
Minimum Uptime (min)	0–60	In auto control mode, the generator cannot automatically shut down if the specified minimum uptime is not reached.
Maximum Uptime (min)	60–2880	In auto control mode, the generator automatically shuts down upon reaching the specified maximum uptime.
Status Detection Interval (min)	1–10	After the generator startup or shutdown command is delivered, if the generator fails to start or shut down when Status Detection Interval is reached, a generator startup or shutdown failure alarm is reported.

Parameter	Value Range	Description
ESS SOC Threshold for Starting Up Generator (%)	15–30	<p>When the battery SOC is lower than ESS SOC Threshold for Starting Up Generator, the generator starts.</p> <ul style="list-style-type: none"> • ESS SOC Threshold for Starting Up Generator \geq End-of-discharge SOC + 10% (For example, if End-of-discharge SOC is 15%, set ESS SOC Threshold for Starting Up Generator to 25% or higher.) • If the generator startup fails, loads will be powered off after the ESS discharges to End-of-discharge SOC. • For details about how to set End-of-discharge SOC for the ESS, see 6.4.2 Setting ESS Parameters in the ESS user manual.
ESS SOC Threshold for Shutting Down Generator (%)	85–100	<p>When the battery SOC is higher than ESS SOC Threshold for Shutting Down Generator, the generator shuts down.</p>
Charge ESS with Generator	<ul style="list-style-type: none"> • Disabled (default) • Enabled 	<p>After this function is enabled, the generator is allowed to charge the ESS.</p>
Rated power (kW)	1–500	<p>Indicates the rated power of the generator.</p>
Max Output Power Ratio (%)	0–100	<p>Indicates the maximum output power ratio of the generator.</p>

Figure 4-13 Battery SOC



4.5.5 Other Parameter Settings

For details about grid connection point parameters, ESS control, demand limit, and optimizer physical layout, see [Parameter Settings](#).

4.6 System Power-Off

Precautions

WARNING

- Before opening the maintenance compartment door, turn off the main circuit breaker, and then turn off the switches for residential backup loads and non-backup loads. Shut down the inverter, and turn off the DC switches of the inverter and ESS.
 - Only authorized personnel can open the maintenance compartment cover to perform electrical connections.
 - Before opening the maintenance compartment cover, turn off the backup load circuit breaker, the grid AC circuit breaker, and two inverter AC circuit breakers inside the SmartGuard. Ensure that the bypass switch is off.
 - After the SmartGuard powers off, the remaining electricity and heat may still cause electric shocks and burns. Therefore, wait for at least 5 minutes and wear insulated gloves before working on the SmartGuard.
-

Procedure

Step 1 (Optional) On the generator control panel, manually shut down the generator.

Step 2 Turn off the main circuit breaker.

Step 3 Power off the inverter.

1. Send a shutdown command to the inverter on the app.
2. Set the **DC SWITCH** of the inverter to **OFF**.
3. (Optional) Install the locking screw for the **DC SWITCH**.
4. (Optional) Turn off the DC switch between the inverter and PV strings.

Step 4 Shut down the ESS.

1. Set the **DC SWITCH** of the ESS to **OFF**.
2. (Optional) Install the locking screw for the **DC SWITCH** of the ESS.

Step 5 Turn off the switches for residential backup loads and non-backup loads.

----**End**

5 Smart Appliance Networking

5.1 Networking Application

In most cases, home appliances continuously consume power after being manually started. If the consumed power is greater than the power generated by PV, the appliances automatically consume electricity purchased from the power grid to meet the requirements. However, if there is surplus PV power, the appliances cannot be automatically started to use the surplus power.

The FusionSolar Smart Power Consumption Solution uses the SmartAssistant as the core of the residential energy management system. In addition to Huawei chargers, you can connect more smart appliances to the PV and energy storage system (ESS) to help you flexibly adjust the working time or modes of appliances and properly allocate energy. The solution also improves the PV power self-consumption rate, reduces power consumption costs, and implements smart power consumption for homes. For example, a charger starts charging when there is a surplus PV power, and a heating rod increases heating power when the electricity price is lower than a specified threshold, to reserve hot water in advance.

Smart appliances can connect to the SmartAssistant through FE or WLAN. The SmartAssistant directly interacts with and responds to the appliances through interface protocols. The smart appliances include third-party chargers (Modbus-TCP), heat pumps (EeBUS and SG Ready), and heating rods (Modbus-TCP).

Other home appliances that do not support direct communication can be connected through smart switches (HTTP). The SmartAssistant sends commands to the wireless module built in a smart switch through WLAN to enable or disable the appliances. (Smart switches include smart sockets, smart relays, and smart circuit breakers.)

Figure 5-1 Smart appliance networking

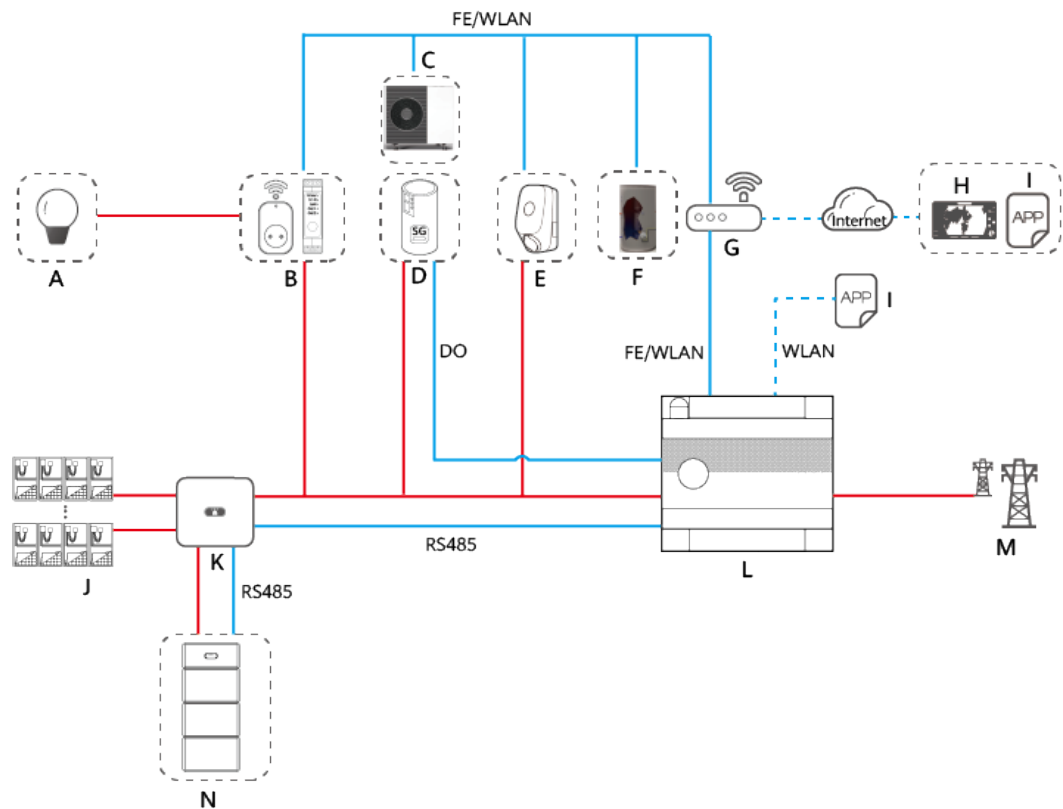

- | | | |
|------------------------|---------------------------|---------------------|
| (A) Power load | (B) Smart switch | (C) EEBUS heat pump |
| (D) SG Ready heat pump | (E) Charger | (F) Heating rod |
| (G) Router | (H) FusionSolar SmartPVMS | (I) FusionSolar app |
| (J) PV string | (K) Inverter | (L) SmartAssistant |
| (M) Power grid | (N) ESS | |

NOTE

- If the power demand of loads exceeds the rated current of the main circuit breaker, the system will turn off the power supply to loads in the ascending order of power demand priority.

Table 5-1 Smart appliance description

Load Type	Description	Maximum Number of Connected Devices
Charger	<ul style="list-style-type: none"> ● Huawei charger: SCharger-7KS-S0 (single-phase), SCharger-22KT-S0 (three-phase) ● Third-party charger: connection through Modbus-TCP <p>For details about charger connection modes, see Table 5-2.</p>	<ul style="list-style-type: none"> ● Huawei charger: 2 ● Third-party charger: 1
Heat pump	<ul style="list-style-type: none"> ● EEBUS heat pump: connection through the EEBUS standard protocol ● SG Ready heat pump^[1] 	1
Heating rod	Connection through Modbus-TCP	1
Smart switch	<ul style="list-style-type: none"> ● Smart socket ● Smart relay ● Smart circuit breaker 	20
<ul style="list-style-type: none"> ● Note [1]: When the SG Ready heat pump provides 12 V power supply, the SmartAssistant directly controls the heat pump. When the SG Ready heat pump cannot provide 12 V power supply, the SmartAssistant controls the heat pump through an external relay. ● A maximum of 40 devices can be connected to the SmartAssistant. ● A Huawei charger must be upgraded to the FusionCharge V100R023C10 to match the SmartAssistant networking. Otherwise, the SmartAssistant cannot detect the charger. Connect to the charger as an installer. For details about the upgrade operations, see E Upgrading the Charger. ● For third-party devices that are not adapted to the system, system commissioning and adaptation are required. If the adaptation is not completed, the devices may fail to be installed and used onsite. For details about the third-party devices which have passed the interconnection test, see the SmartAssistant smart appliance compatibility test list. Note: The manufacturer and seller are responsible for the quality, safety, and related services of the third-party devices. 		

Table 5-2 Connection modes of smart appliances

Charger 1	Charger 2	Connection Mode
Huawei charger	-	<ul style="list-style-type: none"> Connects to the SmartAssistant over FE. Connects to the router over FE or WLAN.
Huawei charger	Huawei charger	<p>Both need to connect to the router over FE or WLAN.</p> <p>Do not connect one charger to the SmartAssistant and the other charger to the router.</p>
Third-party charger	-	Connects to the router over FE or WLAN.
Huawei charger	Third-party charger	<p>Huawei charger: directly connects to the SmartAssistant over FE or connects to the router over FE or WLAN.</p> <p>Third-party charger: connects to the router over FE or WLAN.</p>

 **NOTE**

- It is recommended that the charger and SmartAssistant be connected to the router in wired network (FE) mode. If the charger and SmartAssistant are connected to the router in WLAN mode, the charging power may decrease due to unstable signals.
- If a Huawei charger connects to the router over WLAN, you need to log in to the charger to set the WLAN information before deploying the SmartAssistant.

[Connect to the charger](#) as an installer, choose **O&M > Route Management**, select **WLAN** in **Connection Mode**, and enter the WLAN information.

5.2 Electrical Connections

For details about cable connections in typical scenarios, see the following table.

Table 5-3 Typical scenarios

Cable Connection Scenario	Documentation
Single-phase inverter + LUNA2000-(5-30)-S0 + SmartAssistant	Residential Smart PV Solution Quick Guide (Single-Phase PV+ESS Scenario +SmartAssistant Networking)
Single-phase inverter + LUNA2000-S1 + SmartAssistant	
Single-phase inverter + LUNA2000-(5-30)-S0 + SmartGuard-63A-S0/AUS0	Residential Smart PV Solution Quick Guide (Single-Phase PV+ESS Scenario + SmartGuard Networking)

Cable Connection Scenario	Documentation
Single-phase inverter + LUNA2000-S1 + SmartGuard-63A-S0/AUS0	
Three-phase inverter + LUNA2000-(5-30)-S0 + SmartAssistant	Residential Smart PV Solution Quick Guide (Three-Phase PV+ESS Scenario + SmartAssistant Networking)
Three-phase inverter + LUNA2000-S1 + SmartAssistant	
Three-phase inverter + LUNA2000-(5-30)-S0 + SmartGuard-63A-T0/AUTO	Residential Smart PV Solution Quick Guide (Three-Phase PV+ESS Scenario + SmartGuard Networking)
Three-phase inverter + LUNA2000-S1 + SmartGuard-63A-T0/AUTO	

5.3 Parameter Settings

For details about how to connect smart appliances and set parameters for daily use and the "PV Power Preferred" mode, see the [Smart Power Consumption User Manual](#).

6 Networking with Third-Party Inverters

For a PV-only system with a third-party inverter installed, the Huawei PV+ESS system can be added and an external CT or external meter can be connected to provide a solution for revamping scenarios.

6.1 Networking Application

To facilitate networking with a third-party inverter, ensure that the following version requirements are met:

- SmartAssistant: SmartHEMS V100R025C00SPC115 or later
- FusionSolar app: 25.2.103 or later
- FusionSolar SmartPVMS: SmartPVMS 25.2.0.5 or later

Table 6-1 Recommended external CT specifications

Turn Ratio	Accuracy	Test Point	Percentage at Rated Current				
			1%	5%	20%	100%	120%
≥ 2000 : 1	0.2	Ratio difference (%)	±0.40	±0.20	±0.20	±0.20	±0.20
		Angle difference (')	±30	±15	±10	±10	±10
NOTE <ul style="list-style-type: none"> • Secondary side: 50 mA • Primary side: $N \times 50$ A ($N \geq 2$, and N is an integer) • Cables of the external CT are not routed separately. You are advised to use shielded twisted pair cables. 							

 NOTE

- After **Charge from AC** is enabled for the inverter, the AC power from the third-party inverter is supplied to loads and the surplus power can be charged to the ESS through the Huawei inverter.
- Only statistics on the output power and energy yield can be collected from third-party inverters.
 - The output power is displayed on the energy flow chart (SmartPVMS 25.3.0.5 or later).
 - The energy yield is displayed on the real-time device data page of SmartAssistant.
- Third-party inverters may be uncontrollable. If they are networked, the following impact may occur:
 - In off-grid mode, the PV strings connected to third-party inverters cannot be used for power generation.
 - The power limit at the grid connection point may be exceeded due to uncontrollable power from third-party inverters.
 - The benefits from the SmartAssistant and features involving dynamic electricity prices may not be optimal due to the impact of third-party inverters.
 - If region-specific features such as G100 current limiting, NS protection for shutdown, and shutdown at high feed-in power are triggered, third-party inverters cannot be controlled.
 - Genset power dispatching is not supported.

6.1.1 SmartAssistant Networking

Table 6-2 Supported product models

System Type	Huawei Smart PV Inverter Model	External Meter Model
Single-phase system	SUN2000-(2KTL-6KTL)-L1, SUN2000-(8K, 10K)-LC0, SUN2000-(3K-6K)-LB0, SUN5000-(3K, 6K)-LB0	DDSU666-H, YDS70-C16, DDSU71, DDSU1079-CT
Three-phase system	SUN2000-(5KTL-12KTL)-M1, SUN2000-(12K-25K)-MB0, SUN2000-(5K-12K)-MAP0, SUN5000-(17K, 25K)-MB0, SUN5000-(8K, 12K)-MAP0	DTSU666-H, YDS60-C24, DTSU71, DHSU1079-CT

- When the current at the grid connection point is less than or equal to 63 A, the SmartAssistant is used to measure the energy data at the grid connection point.
- When the current at the grid connection point is greater than 63 A, the external CT for the SmartAssistant or the external meter is required to measure the energy data at the grid connection point.

The external CT for the SmartAssistant or the external meter can be used to measure the energy data of a third-party inverter.

Table 6-3 Networking description

Current at the Grid Connection Point	Connecti on Method	Measuring Energy Data at the Grid Connection Point	Measuring Energy Data of a Third-Party Inverter
≤ 63 A	Method 1	SmartAssistant	External CT for the SmartAssistant
	Method 2	SmartAssistant	External meter
> 63 A	Method 1	External meter	External CT for the SmartAssistant
	Method 2	External CT for the SmartAssistant	External meter

Figure 6-1 SmartAssistant networking with a third-party inverter (external meter)

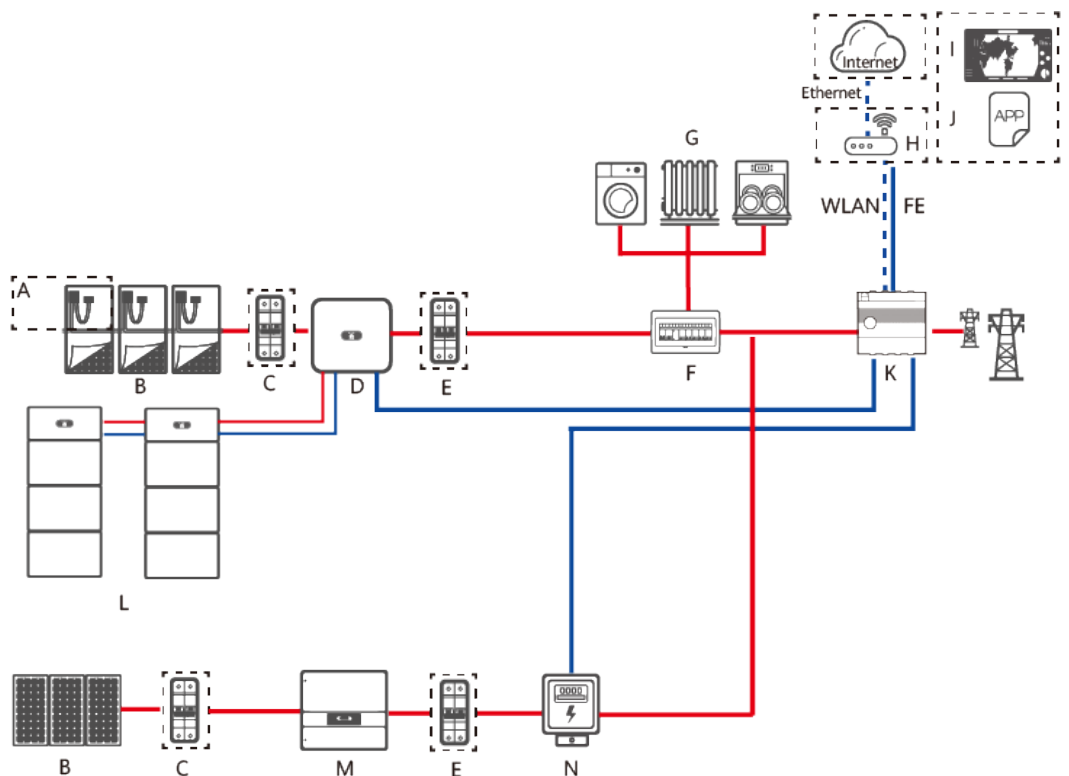

- (A) Optimizer
- (B) PV string
- (C) DC switch
- (D) Huawei smart PV inverter
- (E) AC switch
- (F) AC PDU
- (G) Load
- (H) Router
- (I) FusionSolar SmartPVMS

- (J) FusionSolar app (K) SmartAssistant (L) LUNA2000
(M) Third-party inverter (N) Power meter

Figure 6-2 SmartAssistant networking with a third-party inverter (external CT)

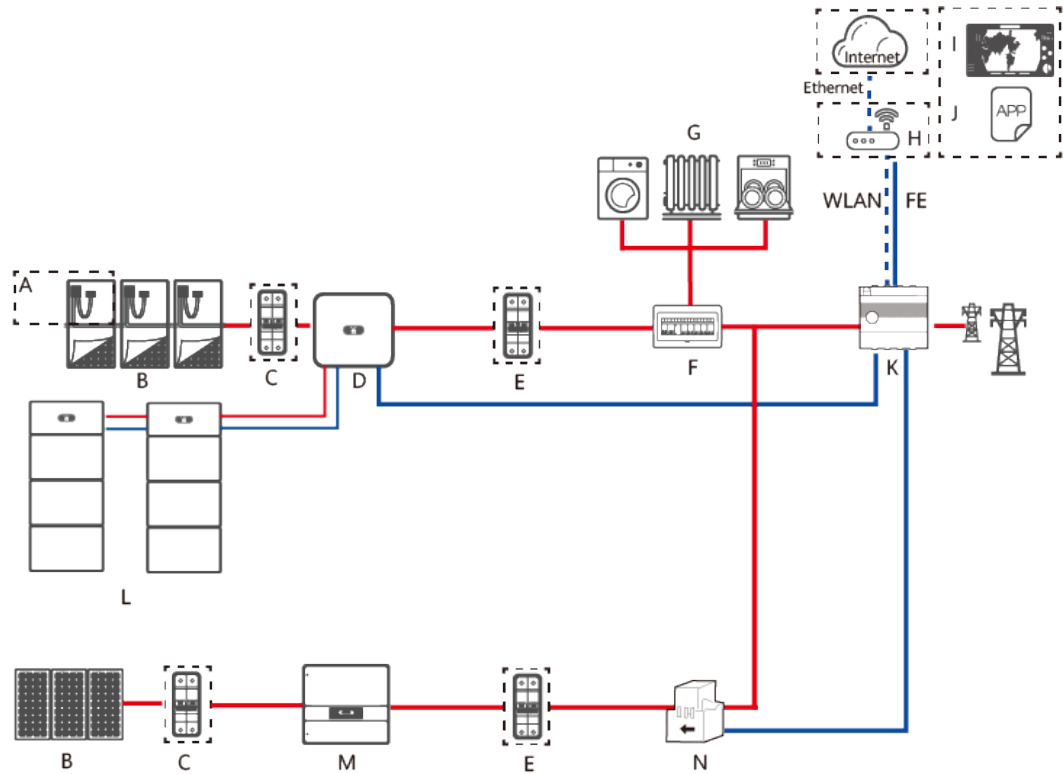

- (A) Optimizer (B) PV string (C) DC switch
(D) Huawei smart PV inverter (E) AC switch (F) AC PDU
(G) Load (H) Router (I) FusionSolar SmartPVMS
(J) FusionSolar app (K) SmartAssistant (L) LUNA2000
(M) Third-party inverter (N) CT

Figure 6-3 SmartAssistant networking with a third-party inverter (external meter and external CT)

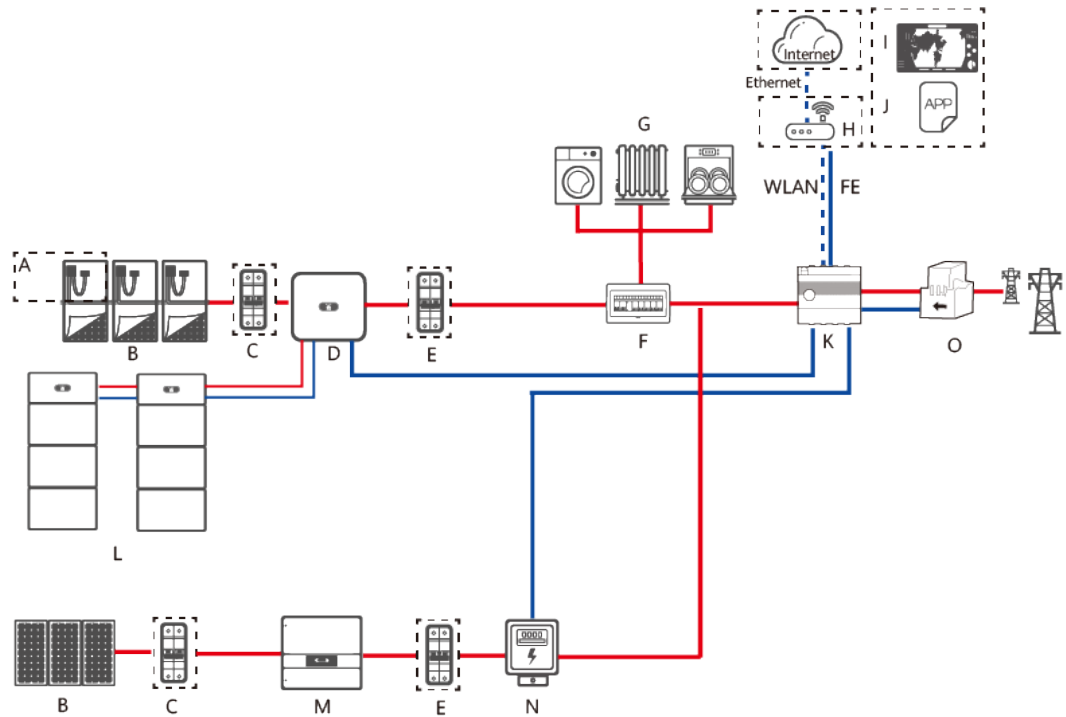

- | | | |
|------------------------------|--------------------|---------------------------|
| (A) Optimizer | (B) PV string | (C) DC switch |
| (D) Huawei smart PV inverter | (E) AC switch | (F) AC PDU |
| (G) Load | (H) Router | (I) FusionSolar SmartPVMS |
| (J) FusionSolar app | (K) SmartAssistant | (L) LUNA2000 |
| (M) Third-party inverter | (N) Power meter | (O) CT |

NOTE

— indicates a power cable, — indicates a signal cable, and - - - indicates wireless communication.

6.1.2 SmartGuard Networking

Table 6-4 Supported product models

System Type	Huawei Smart PV Inverter Model	External Meter Model
Single-phase system	SUN2000-(2KTL-6KTL)-L1, SUN2000-(8K, 10K)-LC0, SUN2000-(3K-6K)-LB0, SUN5000-(3K, 6K)-LB0	DDSU666-H, YDS70-C16, DDSU71, DDSU1079-CT
Three-phase system	SUN2000-(5K-12K)-MAP0, SUN5000-(8K, 12K)-MAP0	DTSU666-H, YDS60-C24, DTSU71, DHSU1079-CT

- When the current at the grid connection point is less than or equal to 63 A, the SmartAssistant is used to measure the energy data at the grid connection point.
- When the current at the grid connection point is greater than 63 A, the external CT for the SmartAssistant or the external meter is required to measure the energy data at the grid connection point.

 **NOTE**

The sum of the currents of Huawei inverters and third-party inverters cannot exceed 63 A. The sum of the currents at the backup and non-backup load ports cannot exceed 63 A.

The external CT for the SmartAssistant or the external meter can be used to measure the energy data of a third-party inverter.

Table 6-5 Networking description

Current at the Grid Connection Point	Connection Method	Measuring Energy Data at the Grid Connection Point	Measuring Energy Data of a Third-Party Inverter
≤ 63 A	Method 1	SmartAssistant	External CT for the SmartAssistant
	Method 2	SmartAssistant	External meter
> 63 A	Method 1	External meter	External CT for the SmartAssistant
	Method 2	External CT for the SmartAssistant	External meter

Figure 6-5 SmartGuard networking with a third-party inverter (external CT)

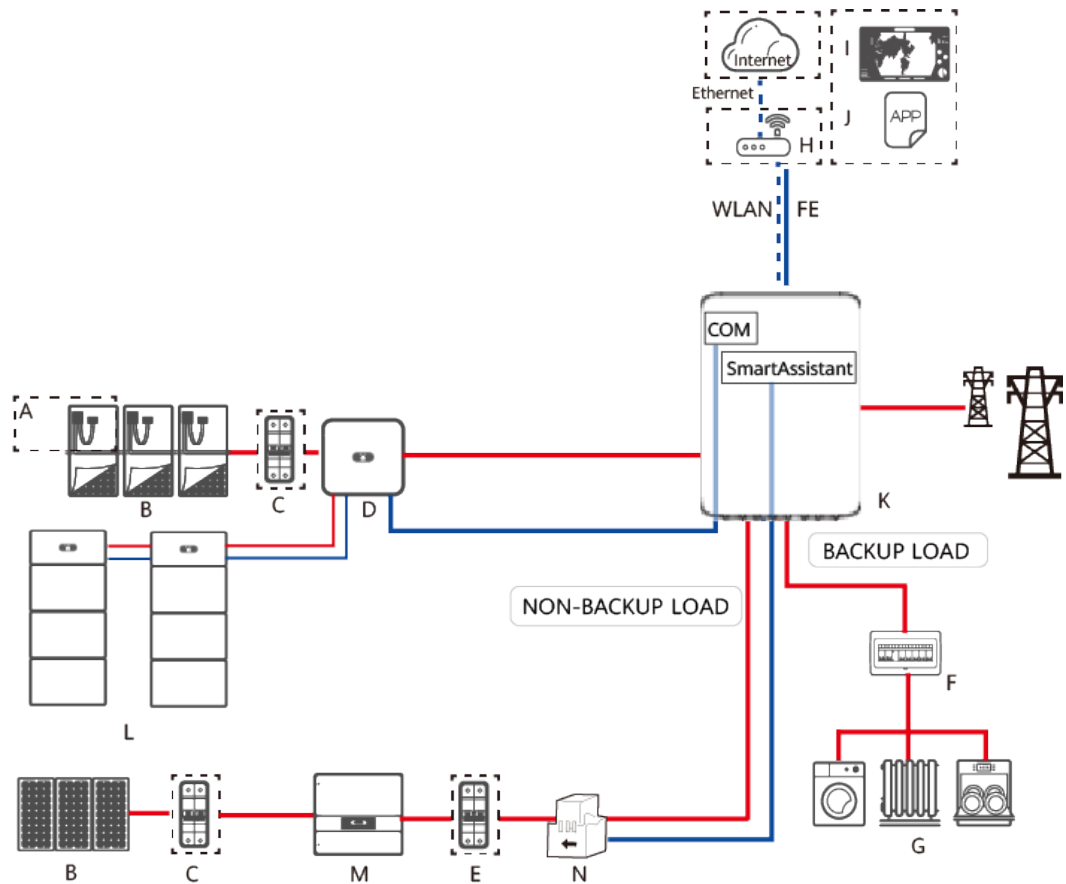

- | | | |
|------------------------------|----------------|---------------------------|
| (A) Optimizer | (B) PV string | (C) DC switch |
| (D) Huawei smart PV inverter | (E) AC switch | (F) AC PDU |
| (G) Load | (H) Router | (I) FusionSolar SmartPVMS |
| (J) FusionSolar app | (K) SmartGuard | (L) LUNA2000 |
| (M) Third-party inverter | (N) CT | |

Figure 6-6 SmartGuard networking with a third-party inverter (external CT and external meter)

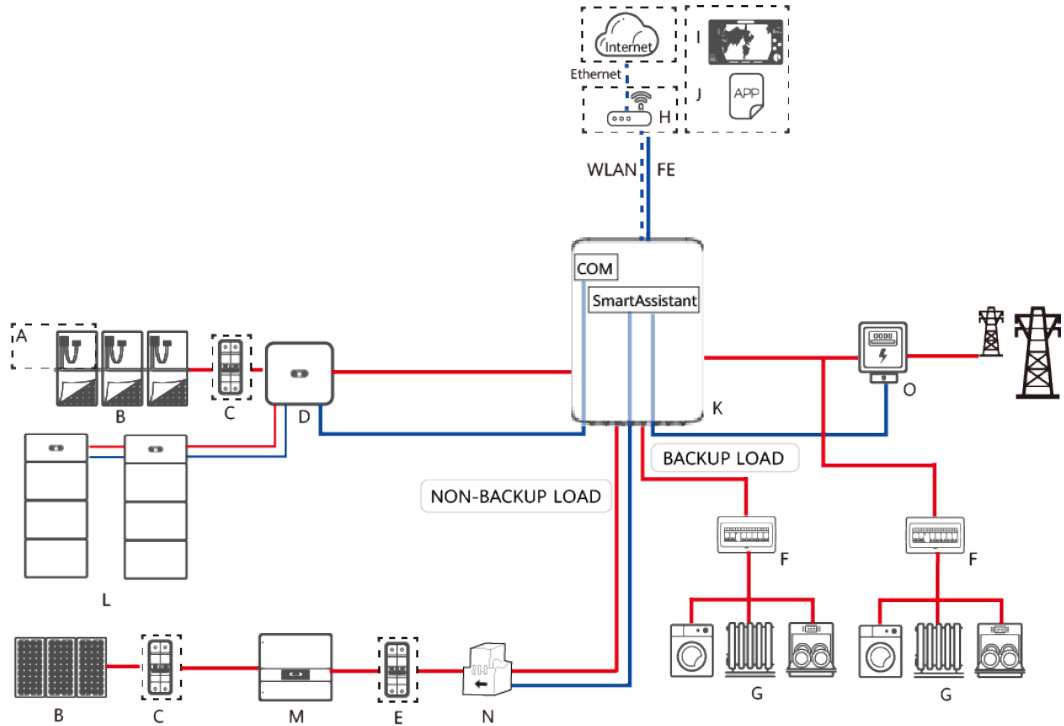

- | | | |
|------------------------------|----------------|---------------------------|
| (A) Optimizer | (B) PV string | (C) DC switch |
| (D) Huawei smart PV inverter | (E) AC switch | (F) AC PDU |
| (G) Load | (H) Router | (I) FusionSolar SmartPVMS |
| (J) FusionSolar app | (K) SmartGuard | (L) LUNA2000 |
| (M) Third-party inverter | (N) CT | (O) Power meter |

NOTE

— indicates a power cable, — indicates a signal cable, and - - - - indicates wireless communication.

6.2 Electrical Connections

The following figures show cable connections in typical scenarios, using a three-phase system as an example. The following table lists the devices shown in the figures.

Table 6-6 Device list

No.	Device
A	Huawei's inverter
B	AC PDU
C	SmartAssistant
D	External meter
E	CT of the meter
F	AC switch
G	Third-party inverter
H	SmartGuard
I	RCD
J	External CT for the SmartAssistant

Note: The CT of the meter is not the external CT for the SmartAssistant. The CT of the meter is used only to measure the data of the external meter.

Figure 6-7 Wiring diagram for SmartAssistant networking with a third-party inverter (external meter)

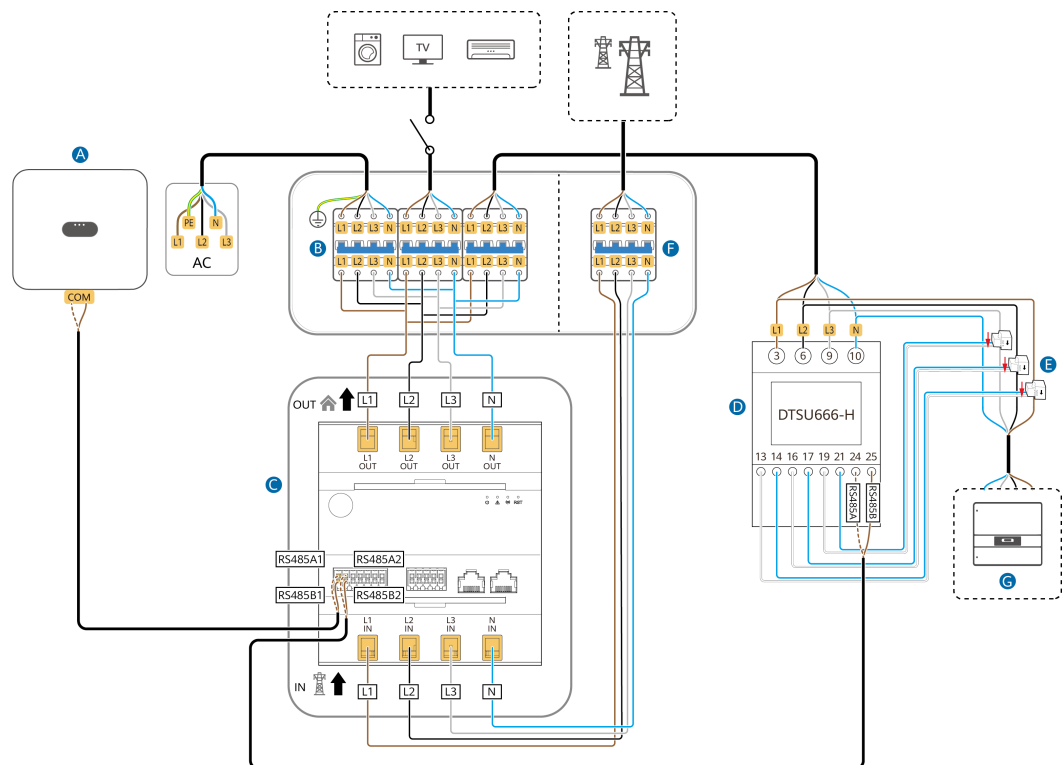

Figure 6-8 Wiring diagram for SmartAssistant networking with a third-party inverter (external CT)

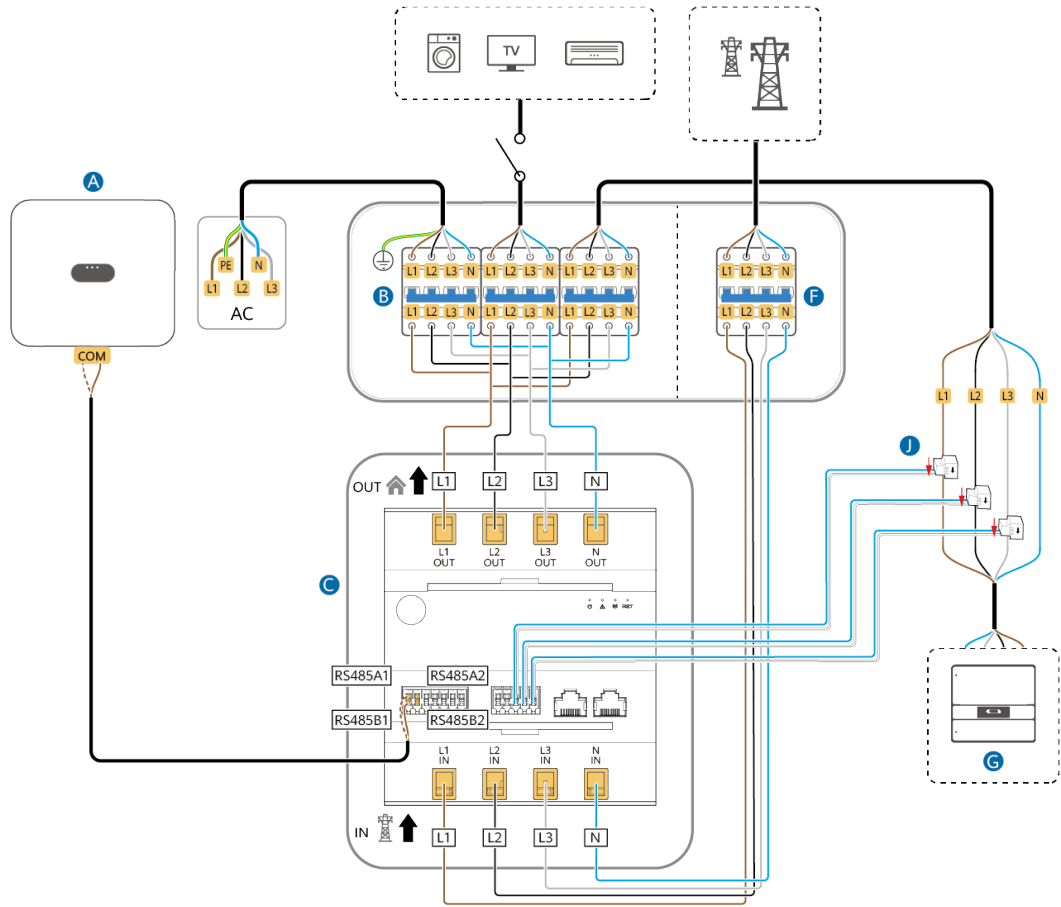

Figure 6-9 Wiring diagram for SmartAssistant networking with a third-party inverter (external meter and external CT)

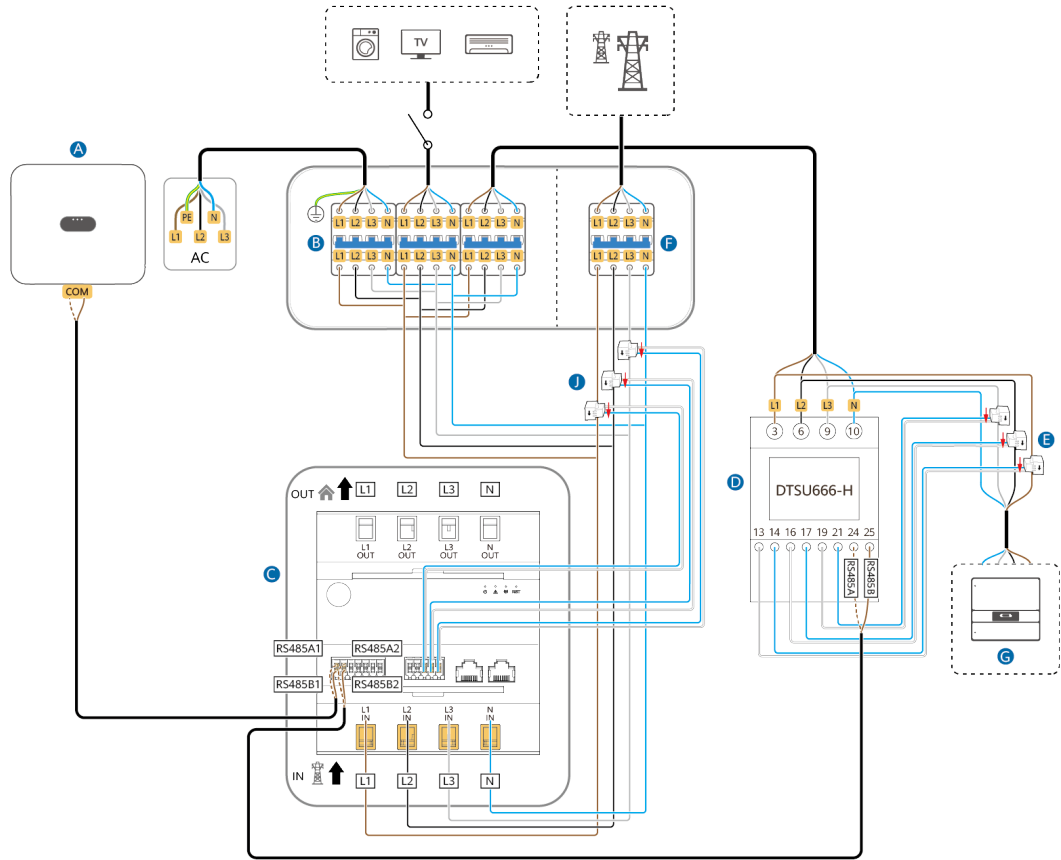
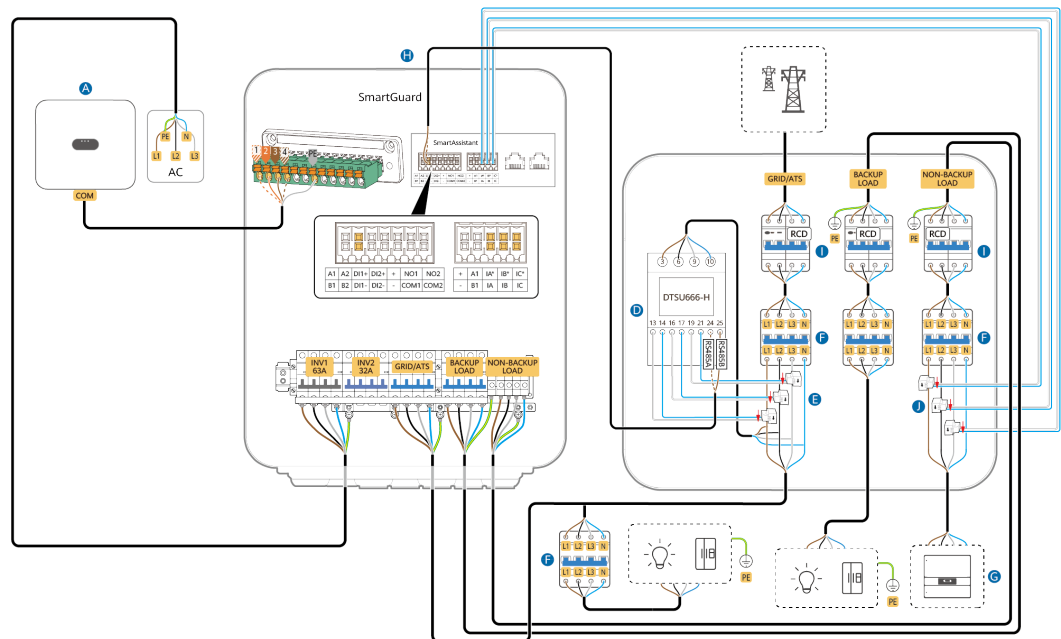

Figure 6-10 Wiring diagram for SmartGuard networking with a third-party inverter (external meter and external CT)



6.3 Parameter Settings

After connecting cables, add the power meter and set parameters for the meter and external CT during deployment and commissioning.

- Choose **Quick Settings** > **Device mgmt**, click **+**, add the external meter to the device list, and set **Meter purpose**.

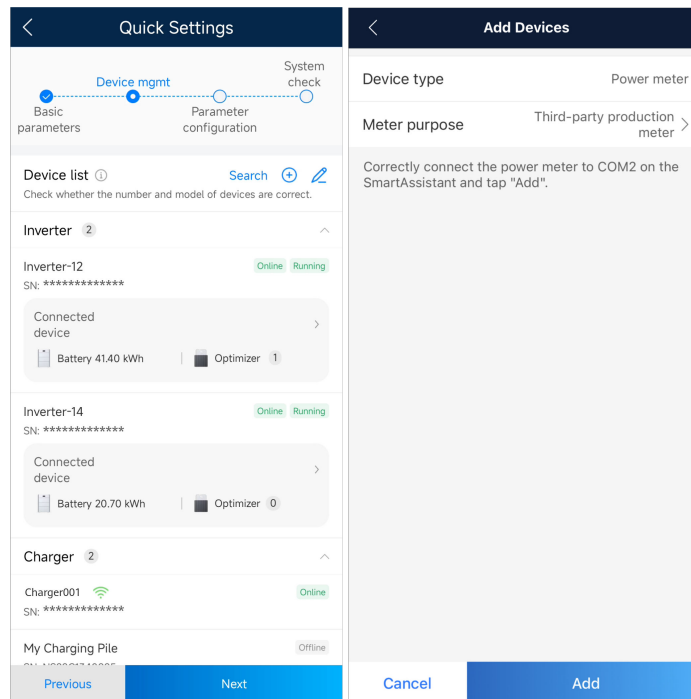

- Choose **Quick Settings** > **Parameter configuration** and set parameters for the external CT.

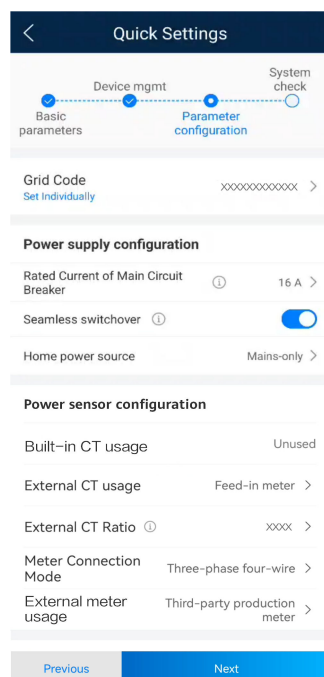

Table 6-7 Power sensor configuration if a third-party inverter is networked

External CT for the SmartAssistant	External Meter	Power Sensor Configuration
-	Connected to a third-party inverter	<ul style="list-style-type: none"> • The default value of Built-in CT usage is Feed-in meter, which does not need to be changed. • Set External CT usage to Unused. • Set External meter usage to Third-party production meter.
Connected to a third-party inverter	-	<ul style="list-style-type: none"> • The default value of Built-in CT usage is Feed-in meter, which does not need to be changed. • Set External CT usage to Third-party production meter. • External meter usage is not displayed.
Connected to the grid connection point	Connected to a third-party inverter	<ul style="list-style-type: none"> • The default value of Built-in CT usage is Unused, which does not need to be changed. • Set External CT usage to Feed-in meter. • Set External meter usage to Third-party production meter.
Connected to a third-party inverter	Connected to the grid connection point	<ul style="list-style-type: none"> • The default value of Built-in CT usage is Unused, which does not need to be changed. • Set External CT usage to Third-party production meter. • Set External meter usage to Feed-in meter.

7 Maintenance and Replacement

7.1 Routine Maintenance

To ensure that the system operates properly for a long term, you are advised to perform routine maintenance as described in this section.

 **CAUTION**

Before cleaning the system, connecting cables, and checking the grounding reliability, power off the system.

Table 7-1 Maintenance checklist

Check Item	Check Method	Maintenance Interval
System cleanliness	Heat sinks are free from obstacles and dust.	Once every 6 to 12 months
System status	<ul style="list-style-type: none">• Check that the SmartGuard is not damaged or deformed.• Check that the SmartGuard does not generate abnormal sound when it is in operation.• Check that ESS parameters are correctly set when the device is running.	Once every 6 months

Check Item	Check Method	Maintenance Interval
Electrical connections	<ul style="list-style-type: none">• Check that cables are securely connected.• Check that cables are intact, especially that the cable sheath contacting a metal surface is intact.• Check that unused AC and DC input ports, COM ports, and waterproof covers on the appliances are locked.	6 months after the first commissioning and once every 6 to 12 months after that
Grounding reliability	Check that the PE cable is securely connected.	6 months after the first commissioning and once every 6 to 12 months after that

7.2 Troubleshooting

If an alarm is generated, rectify the fault by referring to the alarm list in the user manual of the related component.

7.3 Replacing a Charger

1. Remove the old charger.
 - a. Turn off the upstream switch and ensure that the following operations are performed with power off.
 - b. Remove the security torx screws from the bottom of the charger. (Use a TT20 security torx torque screwdriver.)
 - c. Push the charger upwards to separate the charger from its rear cover.
 - d. Remove the communication cable and power cables in sequence.
 - e. Remove the wall-mounting screws and then the rear cover. (Use an M6 torque screwdriver.)
2. Install a new charger. For details, see [Smart Charger User Manual \(SCharger-7KS-S0, SCharger-22KT-S0\)](#).
3. If the charger uses an FE network cable, connect the network cable to the LAN port on the SmartAssistant or the router. If the charger connects to the router over WLAN, log in as the installer user, [C Connecting to a Charger on the App](#), choose **O&M > Route Management**, select **WLAN** in **Connection Mode**, and set the WLAN information.

7.4 Scenario Reconstruction

NOTE

- Re-deployment is required if the SmartAssistant is changed to the Dongle or the Dongle is changed to the SmartAssistant.
- The operations in this chapter are applicable only to Huawei charger.

7.4.1 By the Same Installer

Prerequisites

- The PV devices, charger, and meter have been installed at home and connected to the power plant.
- The charger must be upgraded to the FusionCharge V100R023C10 to match the SmartAssistant networking. Otherwise, the SmartAssistant cannot detect the charger. [Connect to the charger](#) as an installer. For details about the upgrade operations, see [E Upgrading the Charger](#).

Hardware Reconstruction

1. Power off the system.
2. Remove the installed meter.
3. If a Smart Dongle is installed, remove it from the inverter.
4. Install the SmartAssistant and connect cables to the system by referring to [2.2 Electrical Connections](#).
5. (Optional) If the charger is used in wired network mode through an FE network cable, connect the FE network cable of the charger to the LAN port of the router or SmartAssistant.

Deploying a New Plant

1. [Connect the SmartAssistant on the app](#). Perform deployment and device commissioning again by referring to [2.4 Deploying a New Plant](#) and [2.5 Parameter Settings](#).
2. When the charger is connected to the router over WLAN, you need to set the route parameters of the charger so that the charger and SmartAssistant are connected to the same router. Otherwise, the SmartAssistant cannot identify the charger in the network.

Log in to the FusionSolar app as an installer, [connect to the charger](#), and set the WLAN information of the router.

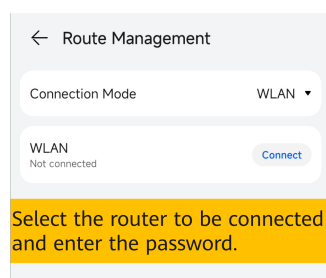

Data Migration

When the Smart Dongle networking or inverter direct connection networking is reconstructed to the SmartAssistant networking, historical plant data will be lost. You can use the **Reconstruct Network** function to migrate historical data such as the energy yields and output power of the source devices to the SmartAssistant to ensure user experience.

NOTICE

- The **Reconstruct Network** function applies only to the scenario where the Smart Dongle networking or inverter direct connection networking is reconstructed to the SmartAssistant networking and the inverter is connected to a meter.
- The **Reconstruct Network** function is supported in FusionSolar app 24.8.0 and later versions.

1. Log in to the app as an installer, connect the SmartAssistant to the plant where the source devices belong, select the plant, and choose : : > **Reconstruct Network**.

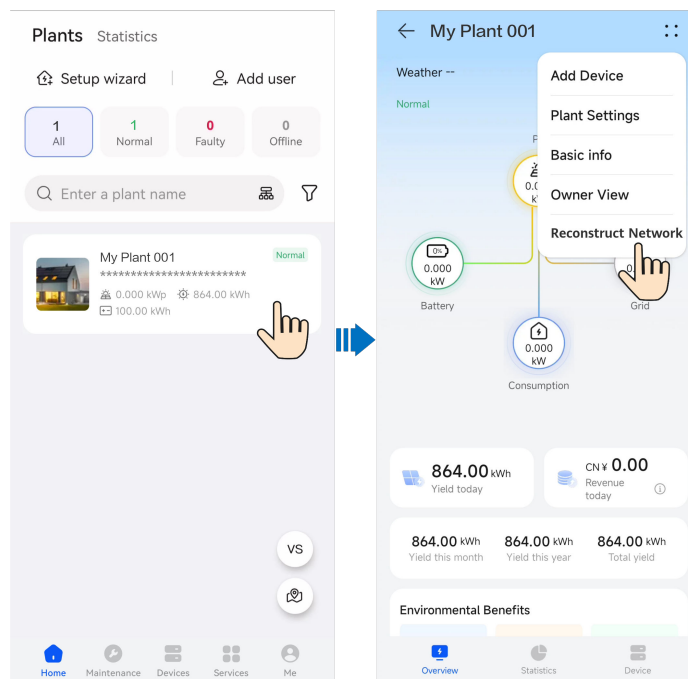

2. On the **Reconstruct Network** screen, tap **OK** and continue the operation as prompted.

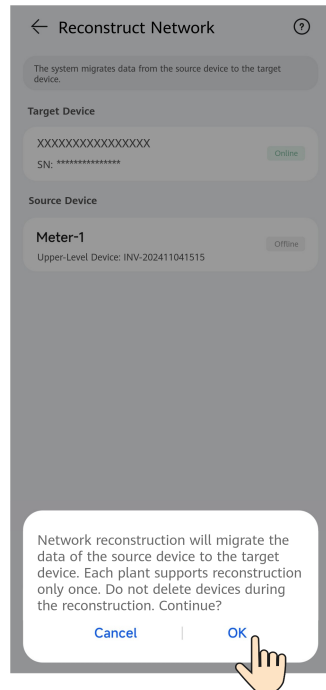

3. Enter the FusionSolar login password to start the data migration task. The system migrates the **Source Device** data to the **Target Device**. The migration task takes about 1–5 minutes. You can tap **Reconstruct Network** to access the **Task Details** screen and view the task progress and status.

NOTE

If **Migration failed** is displayed on the **Task Details** screen, ensure that **Target Device** is in the **Online** state, tap the **Retry** or **Delete** task, and perform **Reconstruct Network** again.

Deleting an Offline Device

After the data of an offline meter is migrated, delete the offline meter from the local commissioning screen and then from the FusionSolar SmartPVMS.

1. Connect the app to the inverter WLAN, log in to the local screen as an installer, and choose **Maintenance > Subdevice management** on the home screen to delete the offline meter.
2. Log in to the FusionSolar SmartPVMS, choose **Monitoring > Device Management**, and delete the offline meter from the plant.

Viewing Data

After the migration is complete, select the corresponding plant in **Home** and view the historical data.

1. View energy management data on the **Statistics** screen.
2. On the **Device** screen, select the inverter and tap **Real-time info** to view the inverter energy yield and output power.

Installing a Charger in the SmartAssistant Networking Scenario

1. Power off the system.
2. Install a new charger. For details, see [Smart Charger User Manual \(SCharger-7KS-S0, SCharger-22KT-S0\)](#).
3. The charger must be upgraded to the FusionCharge V100R023C10 to match the SmartAssistant networking. Otherwise, the SmartAssistant cannot detect the charger. [Connect to the charger](#) as an installer. For details about the upgrade operations, see [E Upgrading the Charger](#).
 - If the charger is used in WLAN mode, log in to the FusionSolar app as the installer, [connect to the charger](#), and set the WLAN of the router.

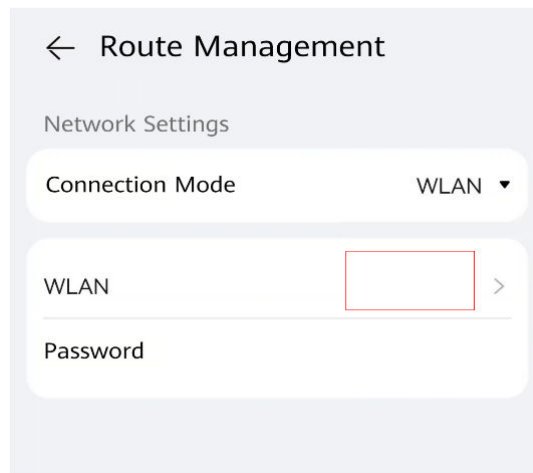

- If the charger is used in wired network mode through an FE network cable, connect the FE network cable of the charger to the LAN port of the router or SmartAssistant.
4. [Connect to the charger](#) as the installer and set the maximum dynamic power.

7.4.2 By Different Installers

NOTE

When the current scenario is reconstructed to the SmartAssistant networking scenario, the owner unbinds the original devices which were bound to plant A by installer A. Then, installer B creates a new plant and reconnects the devices to the plant. The data in plant A is not inherited.

Assume that the PV devices, charger, and FE meter have been installed at home and connected to plant A.

1. Log in to the FusionSolar app as an owner and unbind the devices from plant A.
 - a. Choose **Me > Plant management** and tap the target plant.
 - b. Tap **Add Devices**.
 - c. Tap  and select **Unbind Device** or **Delete Device** based on the site requirements.

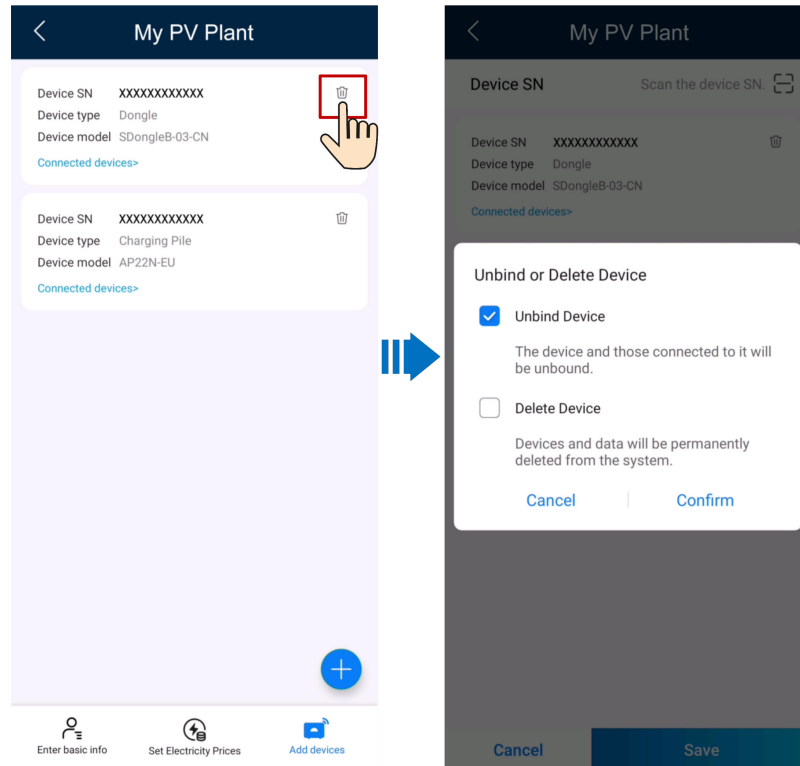

2. The charger must be upgraded to the FusionCharge V100R023C10 to match the SmartAssistant networking. Otherwise, the SmartAssistant cannot find the charger. [C Connecting to a Charger on the App](#) as an installer. For details about the upgrade operations, see [E Upgrading the Charger](#).
3. Power off the system.
4. If a Smart Dongle is installed, remove it from the inverter.
5. Remove the original meter.
6. Install the SmartAssistant and connect cables by referring to [2.2 Electrical Connections](#).
7. If the charger is used in WLAN mode, log in to the FusionSolar app as the installer, [C Connecting to a Charger on the App](#) to the app, and set the WLAN of the router.

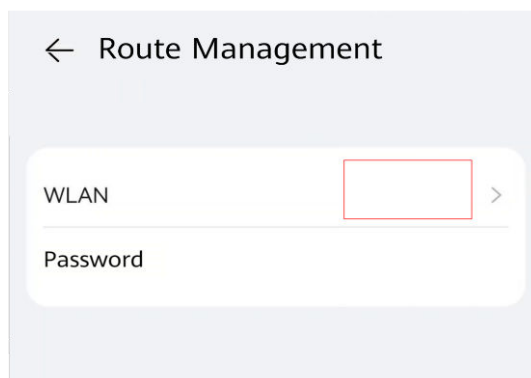

If the charger is used in wired network mode through an FE network cable, connect the FE network cable of the charger to the LAN port of the router or SmartAssistant.

8. Perform deployment and device commissioning again by referring to [2.4 Deploying a New Plant](#) and [2.5 Parameter Settings](#).

Installing a Charger in the SmartAssistant Networking Scenario

1. Power off the system.
2. Install a new charger. For details, see [Smart Charger User Manual \(SCharger-7KS-S0, SCharger-22KT-S0\)](#).
3. The charger must be upgraded to the FusionCharge V100R023C10 to match the SmartAssistant networking. Otherwise, the SmartAssistant cannot find the charger. [C Connecting to a Charger on the App](#) as an installer. For details about the upgrade operations, see [E Upgrading the Charger](#).
4. If the charger is used in WLAN mode, log in to the FusionSolar app as the installer, [C Connecting to a Charger on the App](#) to the app, and set the WLAN of the router.

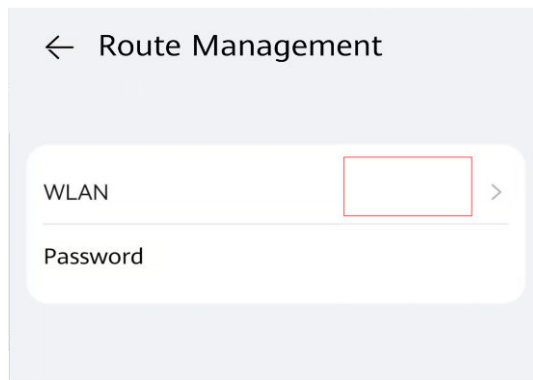

If the charger is used in wired network mode through an FE network cable, connect the FE network cable of the charger to the LAN port of the router or SmartAssistant.

5. [C Connecting to a Charger on the App](#) as the installer and set the maximum dynamic power.

8 Contact Us

If you have any questions about this product, please contact us.



<https://digitalpower.huawei.com>

Path: **About Us > Service Hotlines**

To ensure faster and better services, we kindly request your assistance in providing the following information:

- Device model
- Serial number (SN)
- Software version
- Alarm ID or name
- Brief description of the fault symptom

A Connecting to the Inverter on the App

NOTICE

- When directly connecting your phone to a device, ensure that your phone is within the WLAN coverage of the device.
 - When connecting the device to the router over WLAN, ensure that the device is within the WLAN coverage of the router and the signal is stable and good.
 - The router supports WLAN (IEEE 802.11 b/g/n, 2.4 GHz) and the WLAN signal reaches the inverter.
 - The WPA, WPA2, or WPA/WPA2 encryption mode is recommended for routers. The Enterprise mode is not supported (such as airport WLAN and other public hotspots that require authentication). WEP and WPA TKIP are not recommended because they have serious security vulnerabilities. If the access fails in WEP mode, log in to the router and change the encryption mode of the router to WPA2 or WPA/WPA2.
-

Step 1 Start device commissioning.

Figure A-1 Method 1: mobile phone connected to the Internet

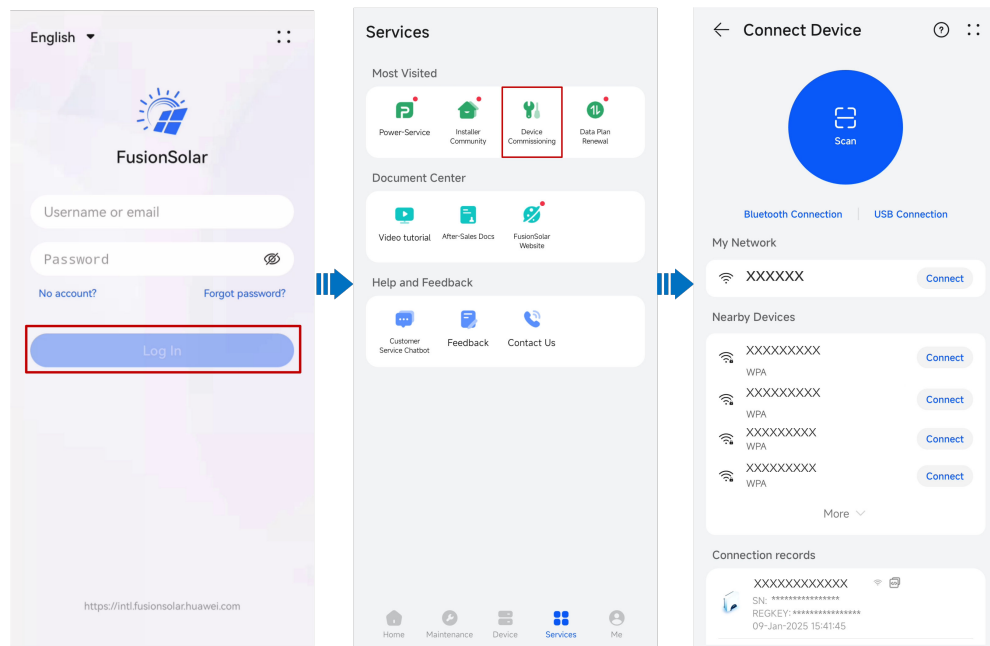
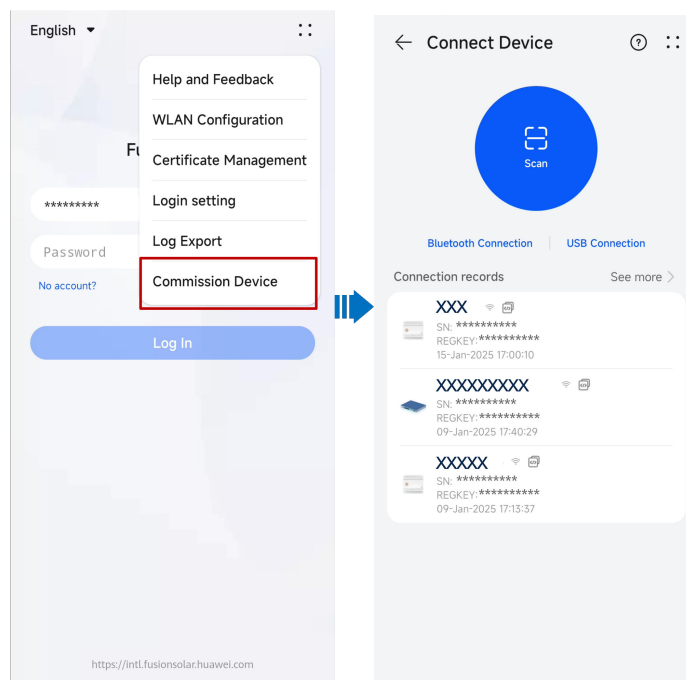

Figure A-2 Method 2: mobile phone not connected to the Internet



NOTE

Method 2 can be used only when no Internet access is available. You are advised to log in to the FusionSolar app to commission devices using method 1.

Step 2 Connect to the inverter WLAN.

Tap **Scan**. On the QR code scanning screen, align the QR code with the scanning box to automatically scan and connect to the WLAN of the inverter.

 **NOTE**

- The WLAN name of a product consists of "Device name-Product SN." (The last six digits of the WLAN name of some products are the same as the last six digits of the product SN.)
- For the first connection, log in with the initial password. You can obtain the initial WLAN password from the label on the device.
- To ensure account security, protect the password by changing it periodically, and keep it secure. Your password might be stolen or cracked if it is left unchanged for extended periods. If a password is lost, devices cannot be accessed. In these cases, the Company shall not be liable for any loss.
- If the login screen is not displayed after you scan the QR code, check whether your phone is correctly connected to the device WLAN. If not, manually select and connect to the WLAN.
- If the message **This WLAN network has no Internet access. Connect anyway?** is displayed when you connect to the built-in WLAN, tap **CONNECT**. Otherwise, you cannot log in to the system. The actual UI and messages may vary with mobile phones.

Step 3 Log in to the device commissioning screen as **Installer**.

NOTICE

- After completing the deployment settings, the installer shall remind the owner to access the local commissioning screen of the device and set the login password of the owner account as prompted.
- To ensure account security, protect the password by changing it periodically, and keep it secure. Your password might be stolen or cracked if it is left unchanged for extended periods. If a password is lost, devices cannot be accessed. In these cases, the Company shall not be liable for any loss.

----End

B Connecting to the SmartAssistant on the App

NOTICE

- When directly connecting your phone to a device, ensure that your phone is within the WLAN coverage of the device.
- When connecting the device to the router over WLAN, ensure that the device is within the WLAN coverage of the router and the signal is stable and good.
- The router supports WLAN (IEEE 802.11 b/g/n, 2.4 GHz) and the WLAN signal reaches the inverter.
- The WPA, WPA2, or WPA/WPA2 encryption mode is recommended for routers. The Enterprise mode is not supported (such as airport WLAN and other public hotspots that require authentication). WEP and WPA TKIP are not recommended because they have serious security vulnerabilities. If the access fails in WEP mode, log in to the router and change the encryption mode of the router to WPA2 or WPA/WPA2.

Step 1 Start device commissioning.

Figure B-1 Method 1: mobile phone connected to the Internet

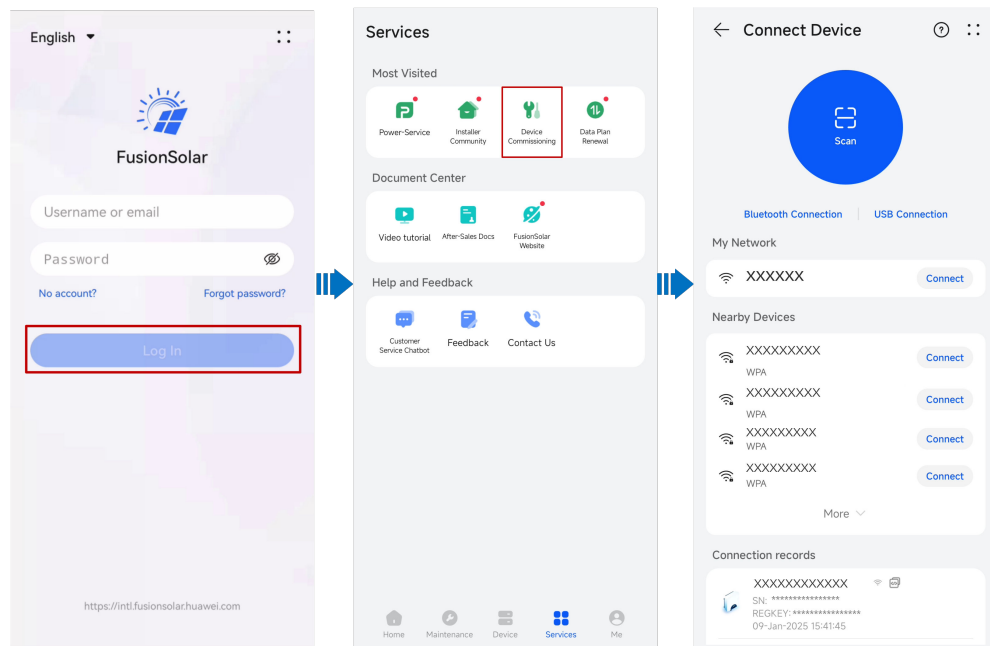
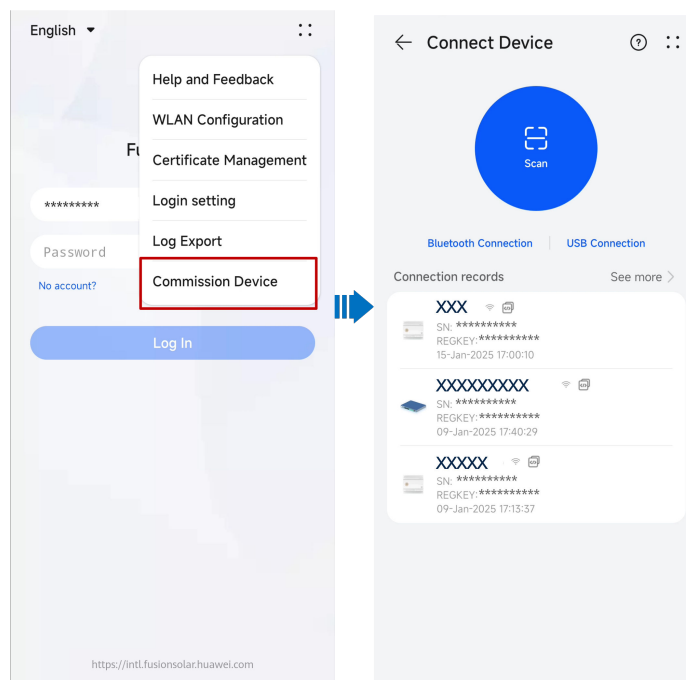

Figure B-2 Method 2: mobile phone not connected to the Internet



NOTE

Method 2 can be used only when no Internet access is available. You are advised to log in to the FusionSolar app to commission devices using method 1.

Step 2 Connect to the WLAN of the SmartAssistant.

Tap **Scan**. On the QR code scanning screen, align the QR code with the scanning box to automatically scan and connect to the WLAN of the SmartAssistant.

 **NOTE**

- SmartAssistant networking: Scan the WLAN QR code of the SmartAssistant.
- SmartGuard networking: Scan the WLAN QR code of the SmartGuard or SmartAssistant.

 **NOTE**

- The WLAN name of a product consists of "Device name-Product SN." (The last six digits of the WLAN name of some products are the same as the last six digits of the product SN.)
- For the first connection, log in with the initial password. You can obtain the initial WLAN password from the label on the device.
- Ensure account security by changing the password periodically. Your password might be stolen or cracked if it is left unchanged for extended periods. If a password is lost, the device cannot be accessed. In these cases, the Company shall not be liable for any loss.
- If the login screen is not displayed after you scan the QR code, check whether your phone is correctly connected to the device WLAN. If not, manually select and connect to the WLAN.
- If **This WLAN network has no Internet access. Connect anyway?** message is displayed when you connect to the built-in WLAN, tap **CONNECT**. Otherwise, you cannot log in to the system. The actual UI and messages may vary with mobile phones.

Step 3 Log in to the device commissioning screen as **Installer**.

NOTICE

- After completing the deployment settings, the installer shall remind the owner to access the local commissioning screen of the device and set the login password of the owner account as prompted.
- To ensure account security, protect the password by changing it periodically, and keep it secure. Your password might be stolen or cracked if it is left unchanged for extended periods. If a password is lost, devices cannot be accessed. In these cases, the Company shall not be liable for any loss.

----End

C Connecting to a Charger on the App

NOTICE

- When directly connecting your phone to a device, ensure that your phone is within the WLAN coverage of the device.
- When connecting the device to the router over WLAN, ensure that the device is within the WLAN coverage of the router and the signal is stable and good.
- The router supports WLAN (IEEE 802.11 b/g/n, 2.4 GHz) and the WLAN signal reaches the charger.
- The WPA, WPA2, or WPA/WPA2 encryption mode is recommended for routers. The Enterprise mode is not supported (such as airport WLAN and other public hotspots that require authentication). WEP and WPA TKIP are not recommended because they have serious security vulnerabilities. If the access fails in WEP mode, log in to the router and change the encryption mode of the router to WPA2 or WPA/WPA2.

Step 1 Start device commissioning.

Figure C-1 Method 1: mobile phone connected to the Internet

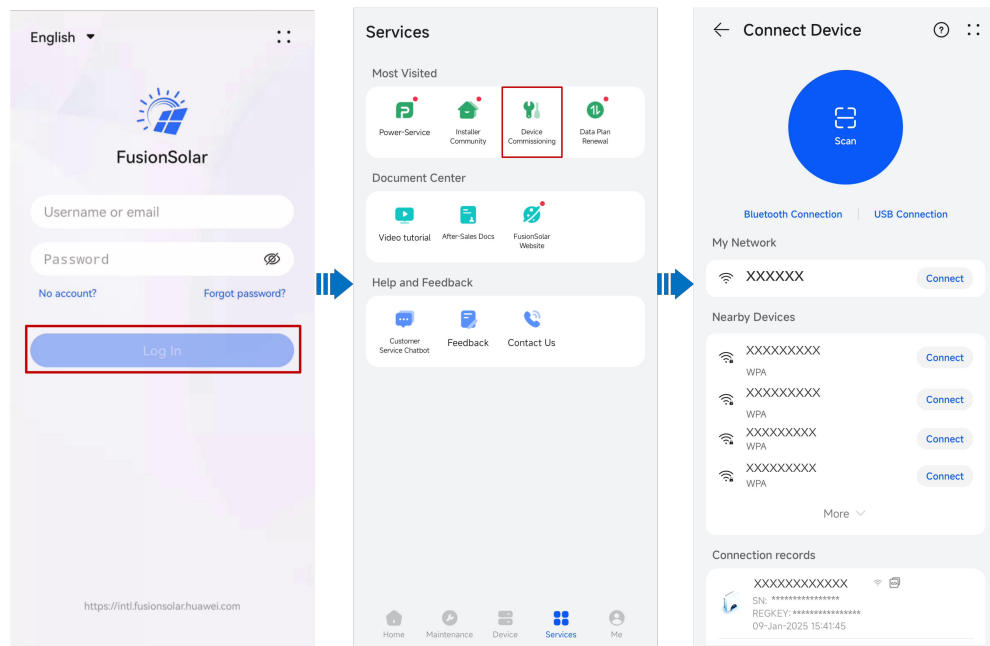
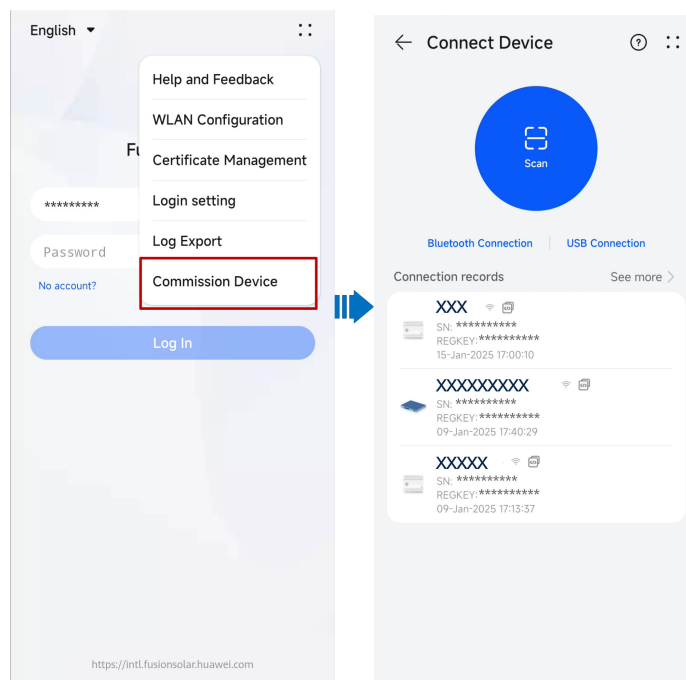

Figure C-2 Method 2: mobile phone not connected to the Internet



NOTE

Method 2 can be used only when no Internet access is available. You are advised to log in to the FusionSolar app to commission devices using method 1.

Step 2 Connect to the WLAN of the charger.

Tap **Scan**. On the QR code scanning screen, align the QR code with the scanning box to automatically scan and connect to the WLAN of the charger.

 **NOTE**

- The WLAN name of a product consists of "Device name-Product SN." (The last six digits of the WLAN name of some products are the same as the last six digits of the product SN.)
- For the first connection, log in with the initial password. You can obtain the initial WLAN password from the label on the device.
- Ensure account security by changing the password periodically. Your password might be stolen or cracked if it is left unchanged for extended periods. If a password is lost, the device cannot be accessed. In these cases, the Company shall not be liable for any loss.
- If the login screen is not displayed after you scan the QR code, check whether your phone is correctly connected to the device WLAN. If not, manually select and connect to the WLAN.
- If **This WLAN network has no Internet access. Connect anyway?** message is displayed when you connect to the built-in WLAN, tap **CONNECT**. Otherwise, you cannot log in to the system. The actual UI and messages may vary with mobile phones.

Step 3 Select a login user and enter the password.

NOTICE

- Use the initial password for the first login. The initial password is **Changeme**. Change the password as prompted after login.
- After completing the deployment settings, the installer shall remind the owner to access the local commissioning screen of the device and set the login password of the owner account as prompted.
- To ensure account security, protect the password by changing it periodically, and keep it secure. Your password might be stolen or cracked if it is left unchanged for extended periods. If a password is lost, devices cannot be accessed. In these cases, the Company shall not be liable for any loss.

----End

D Upgrading the Inverter

 NOTE

If the phone is not connected to a network, prepare the upgrade package before upgrading the inverter.

Connect to the inverter, choose **Maintenance > Upgrade** on the home screen, and select the corresponding inverter version.

E Upgrading the Charger

E.1 Upgrading the Charger Software Version

Prerequisites

- You have obtained the upgrade package from your supplier or Huawei engineers. After the download is complete, use the digital certificate and verification tool available at Huawei technical support website to verify the digital signature of the software package.
 - a. Log in to Huawei enterprise technical support website (<http://support.huawei.com/enterprise>).
 - b. Navigate to or search for **PGP Verify**.
- You have copied the upgrade package to the storage directory of the mobile phone that connects to the charger.

Procedure

1. On the home screen, choose **Maintenance > Upgrade Management**.

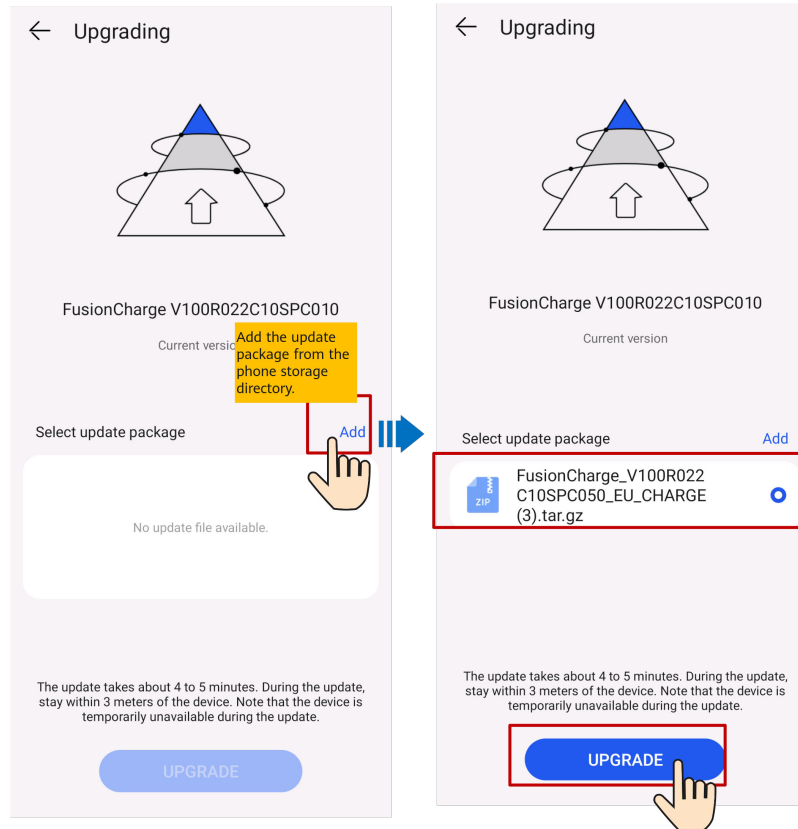

E.2 What Should I Do If the Update Package Obtained from an iPhone Cannot Be Selected on the Update Screen?

Cause

In the iOS system, the update package can be selected only from the software installation path. If the update package is not in the software installation path, the update cannot be performed. You need to place the update package in the installation path before the update.

Procedure

Share the update package to the FusionSolar app.

